



ACCURACY... CLARITY... FLEXIBILITY!

These are essential elements in any modern information display system. They are specific benefits offered the discriminating users of the mini-computer interactive displays developed by ITT's Aerospace Optical Division for the ARTS II system of the U. S. Federal Aviation Administration.

In this Automated Radar Terminal System, radar video and processed beacon data are combined with locally-generated alphanumeric for real-time query/response, target identification and tracking information, all of which is essential to efficient, safe air traffic control.

The resultant data can also be displayed with unique clarity by ITT's BRITE system for control tower application, since the data display is visible under all conditions, even daylight.

These same capabilities have been put to other uses including the Army War Room and the SAC Operational Planning System. In these custom-built

computerized systems, the superb multicolor projection of strategic and tactical data enhances the rapid assimilation necessary to dynamic decision making.

Instant data manipulation and integration of graphics from off-line sources can be precisely controlled by make-up/monitor consoles. Interface capability empowers instant up-date by immediate call-up of alphanumeric, symbols, vectors, circles, conics . . . directly from the mass memory bank.

The proven capabilities of these and similar programs, continually bolstered by the constant evolution of remarkably advanced developments, are solid evidence of A/OD's outstanding accomplishments in the progress of display technology.

Can you use these capabilities? Call for more information from A/OD of ITT, 3700 East Pontiac Street, Fort Wayne, Indiana 46803, 219/743-7571. We'll be glad to display our data.

AEROSPACE/OPTICAL DIVISION



Circle #10 on Readers Service Card

S I D

JOURNAL

The Official Journal of the Society For Information Display
Formerly INFORMATION DISPLAY JOURNAL

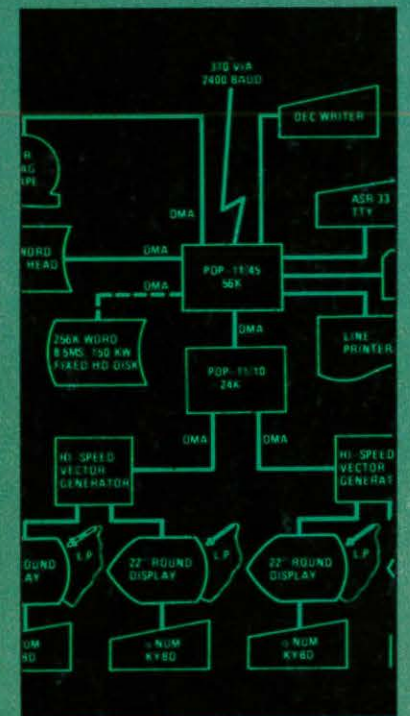
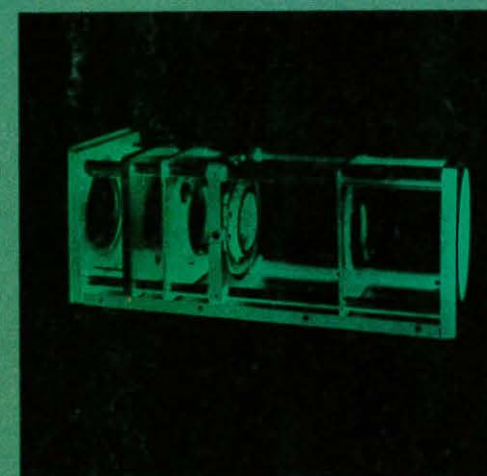
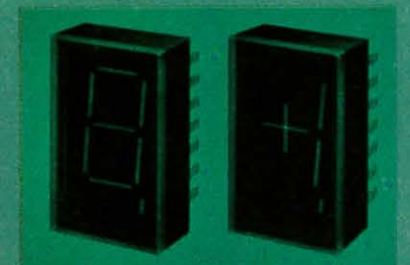
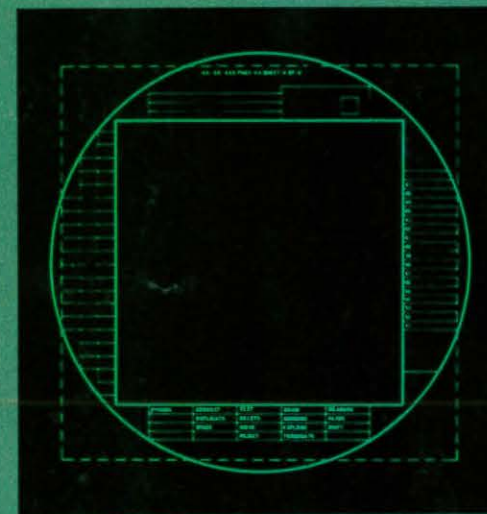

Some Expected and Not So Expected Reactions to A Computer-Aided Design

By JEFFREY FRANKLIN & EDWIN DEAN

Color Graphical Display System

By EIZO YAMAZAKI & KIYOTO OHKAWA

GRID II

By RICHARD PEDERSON

GRID II

vol. 11, Number 3

May/June 1974



syntronic

THE RIGHT PARTS AT THE RIGHT TIME

At Syntronic Instruments we make every effort to keep ahead of the times. That means anticipating materials shortages and planning our production to suit your schedules.

Planning starts with our design engineers who help you select and specify the right precision yoke for your CRT display.

For prototypes and production runs we do our own precision machining, our own tooling, our own molding of intricate parts, and of course, our own coil winding and assembly.

Our own computer installation is used for material requirements planning, production scheduling, bill of materials files and explosions and cost accounting functions which support our purchasing and production activities.

As the largest manufacturer of precision yokes and coils we have a highly specialized organization . . . devoted to getting you the right parts at the right time.

SYNTRONIC INSTRUMENTS, INC.
100 Industrial Road, Addison, IL 60101
Phone (312) 543-6444



Circle #1 on Readers Service Card

SID JOURNAL

The Official Journal of the Society For Information Display

Some Expected and Not So Expected Reactions to A Computer-Aided Design with Interactive Graphics (CANDIG) System

5 By Jeffrey Franklin & Edwin Dean

Introduction of a graphics system, it was felt, would be welcomed. But the reactions to the system from (a) students and (b) experienced users were a little disconcerting to the sponsors.

Color Graphical Display System

14 By E. Yamazaki & K. Ohkawa

A method for simplifying and rendering usable in-plant and/or system-control display boards which threaten to become too complicated for practical operation.

GRID II

22 By Richard Pederson

A minicomputer implementation of an interactive graphic system for the purpose of creation, modification, storage, retrieval, and hard copy of alpha-numeric and geometric data.

Departments

President's Message	4
New Products	27
SID Activities	29
Advertisers Index	30
Sustaining Members	30

table of contents

CLOSING DATES: Editorial closing date is the first of the month preceding month of issue. Advertising closing date is the 15th of the month preceding date of issue.
SUBSCRIPTIONS: U.S., its territories and Canada \$10.00 per year. \$18.00 for 2 years. Foreign Countries \$20.00 per year.
EDITORIAL CONTRIBUTIONS: All material must be accompanied by stamped return envelopes. While all reasonable care will be taken with editorial submissions the publisher assumes no responsibility for art work, manuscripts or photographs.
Copyright 1972 by The Society for Information Display.
Controlled circulation postage paid at Los Angeles, California.

THE OFFICIAL JOURNAL OF THE SOCIETY FOR INFORMATION DISPLAY. Published bimonthly by Blackwell Publishing Company, 1605 Cahuenga Boulevard, Los Angeles, California 90028, 213/463-4891. Correspondence regarding advertising, reprints and subscriptions should be sent to the above address.

Publisher, Robert Black/**Editor,** Erwin A. Ulbrich/**Editorial Coordinator,** Roby Wentz/**Advertising Manager,** William R. Brand/**Production Manager,** Joyce Wallace/**Circulation Manager,** S. Rocklin.

SID NATIONAL OFFICERS: **President,** Robert C. Klein/**Vice President,** Erwin A. Ulbrich/**Secretary,** Thomas V. Curran/**Treasurer,** Bernard J. Lechner.

National Office Manager . . . Violet Puff

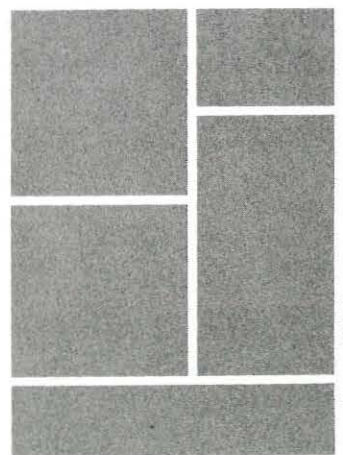

may/june-1974

vol. 11, number 3

SID Second Quarter Proceedings Issued

Availability of the **Second Quarter Proceedings** is announced by the Society for Information Display. The Proceedings volume contains four articles, as follows:

LEGIBILITY RESEARCH

By D.A. Shurtleff, Mitre Corp., Bedford, Mass.

VISUAL CAPACITY

An Image Quality Descriptor for Display Evaluation

By R.W. Cohen and I. Gorod, RCA Laboratories, Princeton, N.J.

DISPLAY DEVICES

A Perspective on Status and Availability

By I. Reingold, AMSEL-TL-BD, Ft. Monmouth, N.J.

A PLASMA PANEL INTERACTIVE GRAPHIC SYSTEM

By D.L. Fulton, Bowling Green State University, Bowling Green, O.

The Proceedings go to all members of the Society for Information Display as part of their membership. Cost to non-members and libraries is \$9.00 per copy.

MEMBER'S MESSAGE PRESIDENT'S MESSAGE

"The Society for Information Display was founded in April 1963 to provide the proper environment for information exchange between individuals involved in information display technology." This familiar statement is a summary of SID's aims and purposes and can be found in much of the Society's promotional material.

But what is information display technology? By the most parochial definition it deals with the mechanisms which allow humans to perceive information. Were we to accept this, our interests would include everything from newsprint to billboards. Ridiculous?

The exceptionally successful 1974 SID International Symposium held May 21-23 in San Diego, California, included several papers dealing directly or peripherally with the printed page. (The Micrographics/Computer Information Display System, R.L. Merwin; Document Storage and Retrieval, L. Housman; Systems Aspects of Displays, D.E. Liddle) as well as a paper describing a classical billboard (A Light-Reflecting Electromagnetic Display, H.O. Pepruik). The fact that the information on that billboard can be changed remotely does not alter the genus of this device.

It is hardly necessary to review SID's involvement with device technology. Our publications are filled with examples of methods for generating displays, large and small; techniques for controlling the transmission, reflection and generation of light; schemes for enabling and simplifying the addressing of a variety of matrixes; etc.

If we are tempted to dismiss the printed page from SID's purview, we need but consider the complexities of text editing and entry systems, computer aided font generation, type setting using CRT and laser technologies, and these problems justify our attention.

I submit that information display technology, as intended in our aims and purposes, encompasses all non-trivial scientific effort associated with the generation of active or passive presentation of information. I do not believe that the sophistication of the final product alone is a rational determinant for SID's involvement. Rather, the techniques utilized in achieving the objective — the special hardware, software, system implementation — should establish whether the work merits the attention of the Society's members.

SID has always been an interdisciplinary organization. With emphasis on display, we touch on human factors, computer software, electron device technology, optics, etc., to produce the desired visual results. Other technical societies are dedicated to those disciplines and we welcome the opportunity to engage in mutually beneficial technical activities with such groups.

The 1974 Conference on Display Devices and Systems, to be held October 9-10, 1974, in New York, and sponsored jointly by the Society for Information Display, the Electron Devices Group of the IEEE, and the Advisory Group on Electron Devices of DOD, is only one example of many such future activities.

Robert C. Klein
President

EDITORIAL BOARD: Chairman, Erwin A. Ulbrich, McDonnell-Douglas Astronautics/Thomas V. Curran, Information Displays, Inc./George Kaelin, Motorola, Inc./Violet Puff, Society for Information Display/A. H. Wisdom, TRW Systems Group.
SID National Headquarters/654 N. Sepulveda/Los Angeles, Calif. 90049/Tel. 213/472-3550

some expected and not so
expected reactions to a

COMPUTER-AIDED DESIGN WITH INTERACTIVE GRAPHICS (CANDIG) SYSTEM

Introduction of a graphics system, it was felt, would be welcomed. But the reactions to the system from (a) students and (b) experienced users were a little disconcerting to the sponsors. Here is told how students and others reacted.

By JEFFREY FRANKLIN and EDWIN DEAN
Naval Ordnance Laboratory
White Oak, Silver Spring, Maryland

□ Experience using computer analysis codes for electronic circuits yielded two facts that seem to hamper a powerful tool. First, most engineers do not want to take the time to learn coding. Second a large number of time-consuming errors are made in the batch mode.

As an illustration of the problems associated with batch operation of the codes, these steps are associated with their usage:

(1) A schematic is coded into the computer language associated with the code being used.

(2) Cards are punched.

(3) The job is submitted to be run by the computer.

(4) Keypunch errors listed in the output are corrected.

(5) If there are coding errors listed in the output, a schematic must be drawn from the coding and checked against the original schematic.

Steps (2) through (5) are then repeated until all the errors are removed and the code gives the circuit response requested. From this point on, the job is repeatedly resubmitted with different output requests, different values of the circuit elements, or an altered circuit topology until a complete analysis of the circuit is obtained.

By JEFFREY FRANKLIN
& EDWIN DEAN

As a result of this process and of the low acceptance of the codes, it was decided that a computer graphics input and output system should be developed. The objective of graphics would be to divorce the use of the analysis codes from traditional language programming. The only operation the user would have to perform would be to draw the circuit on the face of a cathode ray tube (CRT). This would eliminate the excessive time required to learn the circuit languages, to acquire programming skills, to become proficient at keypunching, and to redraw the circuit from the code. The output from the circuit would be displayed on the CRT, i.e. there would be essentially zero turn-around time for a job. Thus, the user could perform any changes he desires and see the results immediately. Whereas, with a batch job, a complete analysis would take days or weeks; computer graphics analysis would take only hours.

Anti-Loss Safeguards

The current graphics version (Figure 1) has graphical editing, rotation of elements, and graphically requested circuit output. In addition, alphanumeric (such as element values) are not displayed on the screen unless requested. This latter feature was implemented because it was found that the alphanumerics associated with each circuit element take up more space than the circuit diagram itself. This latest version is written from a fail-safe viewpoint. In order to minimize the loss due to a main frame computer crash, the circuit and its associated information are saved on tape with every five elements drawn. Thus a main frame crash can at most cost a five element loss while drawing the circuit. Once the system drawing has been completed, the tape serves as documentation.

Since the screen is finite in size and the circuit being analyzed is often larger than could fit on the screen, a method was devised to solve this problem. The graphics options available were zooming (i.e. magnifying part of a schematic to cover the complete screen), windowing (i.e. the ability to move a viewable window over a large virtual schematic),

paging (i.e. the ability to work with fixed pages, the totality of which compose the complete schematic), or subcircuit formation (i.e. the ability to define a schematic as a subcircuit with a name and symbol for use in creating the system schematic). The subcircuit formation option was chosen since engineers tend to think in this manner.

Method of Nesting

The subcircuit concept was generalized by creating the ability to nest one subcircuit within another. Nesting begins by representing a subcircuit by a symbol. Whenever this symbol is used in another circuit, it is like connecting the subcircuit into the new circuit. The new circuit can be defined by another new symbol and used in another main circuit. Figure 2 shows the nesting process.

The graphical implementation of nesting is merely to draw a circuit and define a menu symbol for it. This menu symbol then becomes available to be used in drawing other circuits. The user can exercise an option to see and/or alter the circuit represented by this symbol.

Operation of the system is shown in Figures A through L. The menu which contains the choices of elements from which the user may build his circuit is shown on the right side of the screen. To build the circuit, the user positions the tracking cross and with the light pen, picks the appropriate menu symbol to bring up

the element at the position of the tracing cross. To pick up succeeding elements the process is repeated. Elements can be joined by lines of arbitrary length. At any time, the user can change the topology of the circuit drawn (i.e. edit). A hard copy can be made of what is on the CRT by picking "hcopy" with the light pen. Figure M shows a hard copy of the circuit elements for element currents. The response of the circuit is returned to the graphics (Figure N). The user can redisplay his circuit for further changes (i.e. to continue his analysis).

Feedback From Student Users¹

The Computer Aided Network Design by Interactive Graphics (CANDIG) system was part of an in-house course on computer aided circuit design and analysis. The class was given a half-hour film lecture, a half-hour demonstration at the terminal, and each class member received about a half-hour hands on practice with an instructor. Most of the class had little or no previous experience with circuit analysis codes and programming.

The general reaction was that graphics was an interesting innova-

¹For the views and experiences of the developers of the system see: J. Franklin and E. Dean, "Interactive Graphics for Computer Aided Network Design," Proceedings of the National Computer Conference, Vol. 42, June 1973.

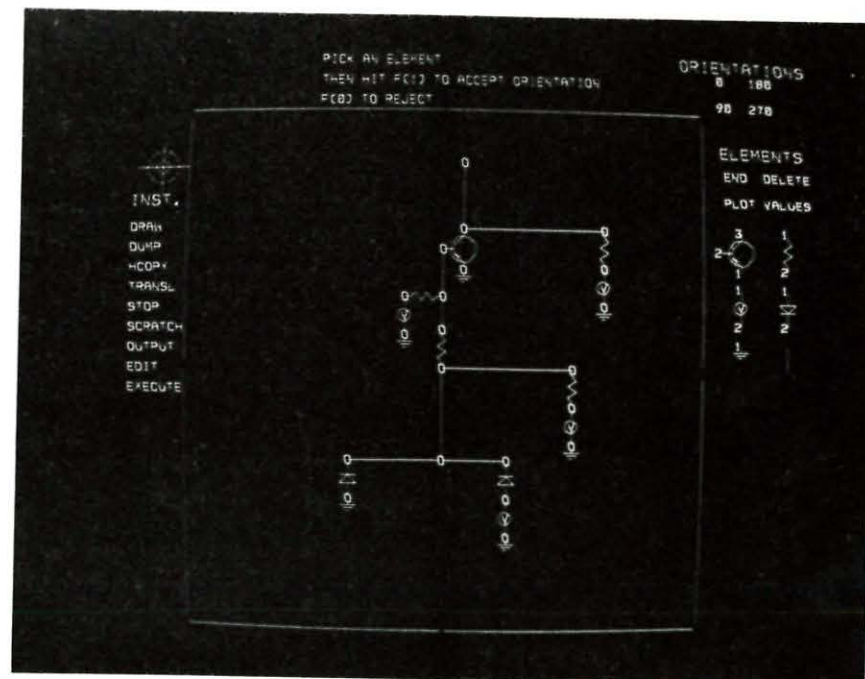
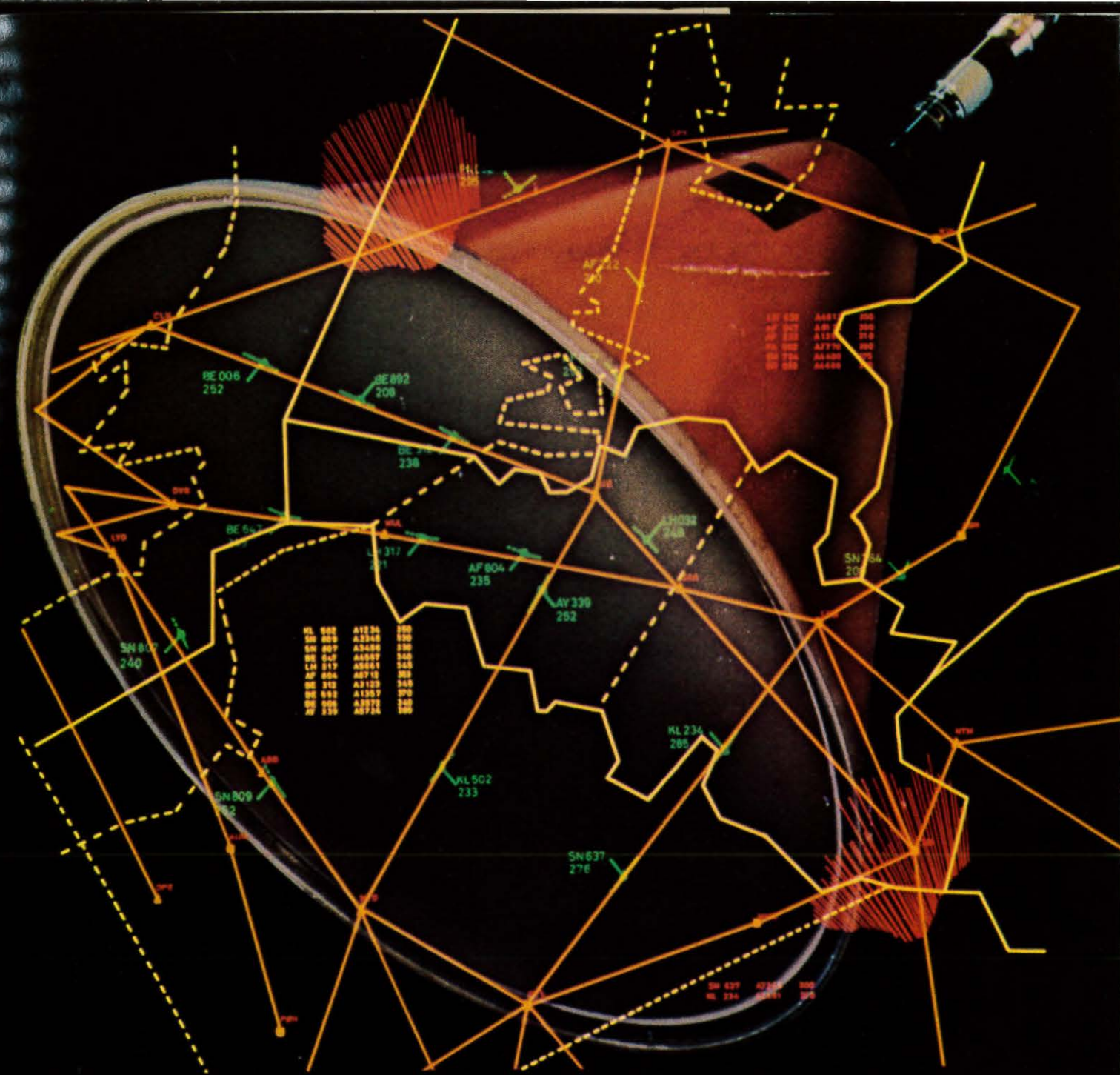

Figure 1. Third Version Display



Multicolor, multipersistence and a large flat screen. All in one CRT.

That's the way to increase the legibility of your display. With our CRTs you can have a flat surface as large as 22", superior brightness, exceptional contrast and an optional dual persistence capability as well.

That means you can display such rapidly-moving information as aircraft identification labels and

position symbols next to the display of low repetition-rate video—without confusion. Phosphor persistence and color can be selected by voltage switching to present radar targets in one color and to write computer-generated characters and air routes in another color.

By varying the voltage of a single

electron beam scanning a multiphosphor screen, we've achieved outstanding brilliance and contrast. And resolution that's comparable to that of high quality monochrome CRTs.

For complete information on our color CRTs, circle the appropriate number on the reader's service card, or contact us directly.



THOMSON-CSF

MARKETED IN NORTH AMERICA BY DUMONT ELECTRON TUBES & DEVICES, CLIFTON, N.J. / TEL (201) 773-2000
France - THOMSON-CSF Groupement Tubes Electroniques/8, rue Chasseloup-Laubat/75377 PARIS CEDEX 15/Tel. 566 70.04
Germany - THOMSON-CSF Elektronenröhren GmbH/Am Leonhardstr. 10/6 FRANKFURT/MAIN/Tel. 70 20.99
Italy - THOMSON-CSF Tubi Elettronici SRL/Viale degli Ammiragli 71/ROMA/Tel. 636 14.58
Japan - THOMSON-CSF Japan K.K./Kyosha Building/1-9-3 Hiraoka-cho/Chiyoda-ku/TOKYO/1102/Tel. (03) 264.6341
Sweden - THOMSON-CSF Elektronrör AB/Box 27080/S 10251 STOCKHOLM 27/Tel. (08) 22 58.15
United Kingdom - THOMSON-CSF Electronic Tubes Ltd./Bilton House, Uxbridge Road, Ealing/LONDON W 5 2TT/Tel. (01) 579 55.11/Telex: 25 659

Circle #2 on Readers Service



SEE US AT
THE I.E.E.E.
BOOTHS 2303-05
2402-04

Here's Ramtek's new color graphic display system, the FS 2000, for the manager who has nothing—but gauges, strip charts, plot boards and so forth.

Who needs it?

Anyone responsible for process supervision, power utility control or financial management information processing.

Ramtek introduces the FS 2000 System for the manager who is involved in monitoring the flow of raw materials through his industrial process to a profitable conclusion.

We've utilized the design experience of our highly successful GX 100 Series System and applied it to the development of the FS 2000 System. Here's what the new system offers:

- The ability to address a character to any location on a 256 x 256 grid.
- Four character sizes, the smallest of which allows 85 characters per line.
- Graphic line generation of any thickness or length with four bytes—only one byte required to modify either.
- Automatic overwrite of a character on a graphic entity—no erase step necessary.
- Ability to overlay or completely overwrite characters non-destructively allowing convenient combinations.
- Two byte relocation of any display block—allowing convenient "visual subroutines."
- Dual intensity available on each of seven colors.
- Ability to blink any entity from full brightness to half brightness or off.

Need more information? Contact: Ramtek Corporation, 292 Commercial Street, Sunnyvale, California 94086. Telephone (408) 735-8400

RAMTEK CORPORATION
THE GRAPHIC DISPLAY COMPANY

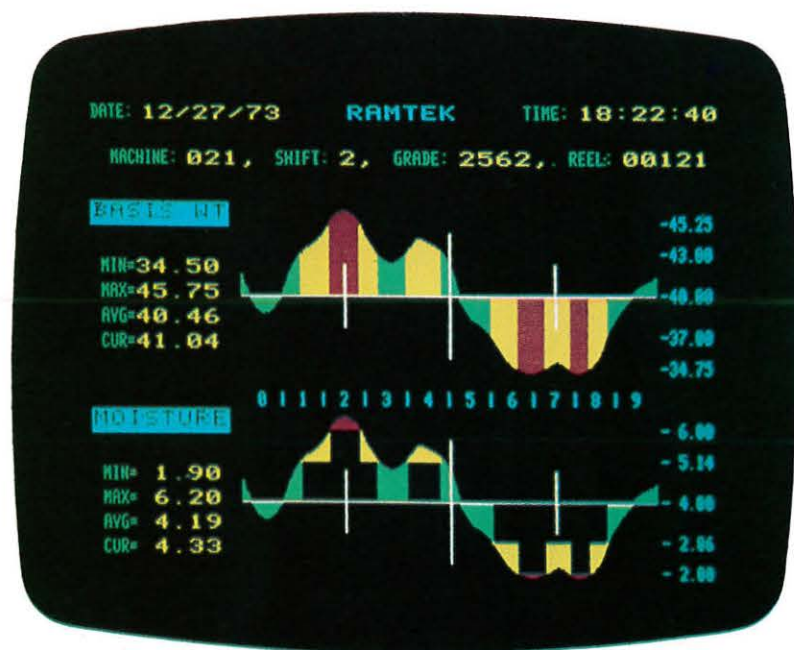

Circle #3 on Readers Service Card

tion. Users unanimously agreed that a person could be using the system without the aid of an instructor in about a half-hour to an hour.

These types of reactions were expected because the system had been designed with these goals in mind. However, there were other reactions that were never expected. One unexpected reaction was that people preferred card (batch) input to learn with because they felt that the errors they were making were not as severe or costly. Another fear was that their slow use of the graphics system in

their learning phase would tie up the main frame computer. (We have a CDC graphics terminal on line driven by a CDC 6400.) These inexperienced users felt pressured because the graphics system would instantaneously feed back errors they had made.

In our graphics system, there is a dedicated peripheral processor driving a refresh terminal. The user pays a wall clock fee for this peripheral processor. Thus users felt they were in a race with the computer. It was as if, when they looked at the terminal

By JEFFREY FRANKLIN & EDWIN DEAN

screen, they saw all the way through to the central processor unit and a million dollars worth of electronics staring back at them, which they felt obligated to use efficiently. One student said the reason he would rather use cards was because he did not mind making mistakes on the key punch because it wasn't hooked to a computer, it was just a key punch machine. Other students made similar



Figure a. Third Version Display



Figure b. Menu of Available Circuit Elements

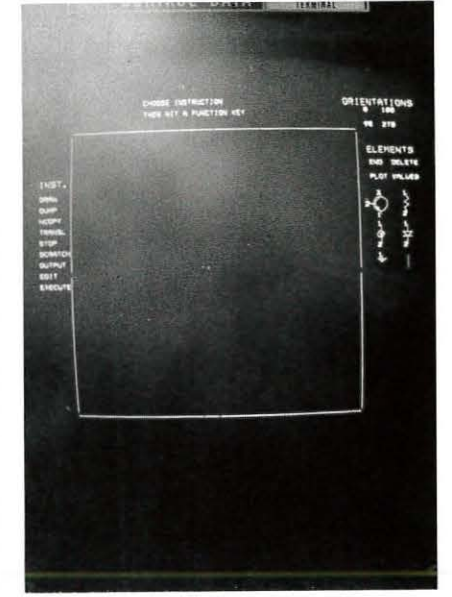

Figure c. Third Version Display

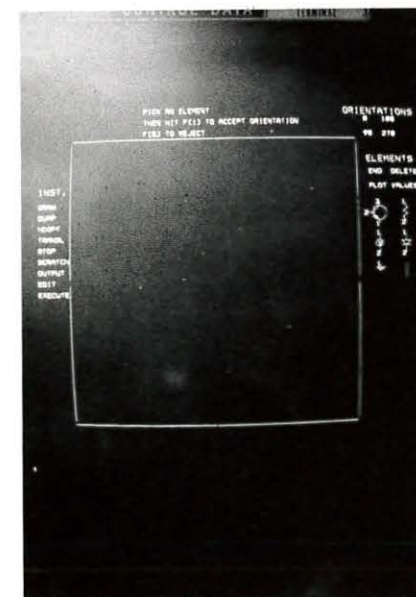

Figure d. Third Version Display

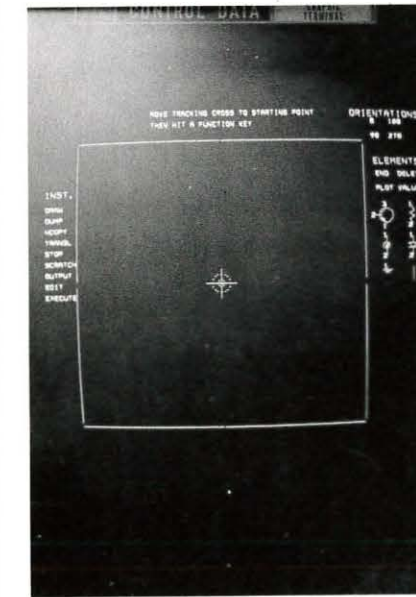

Figure e. Third Version Display

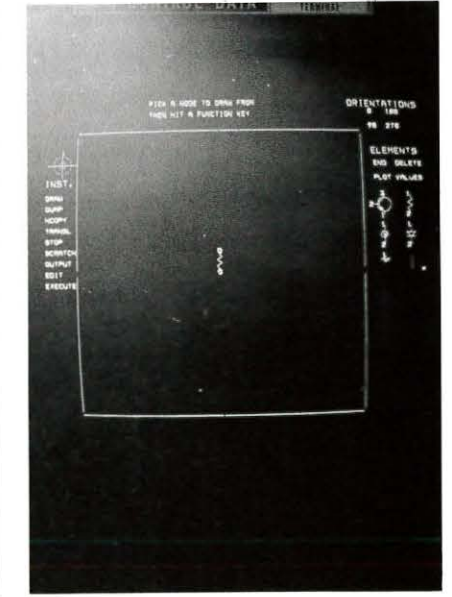
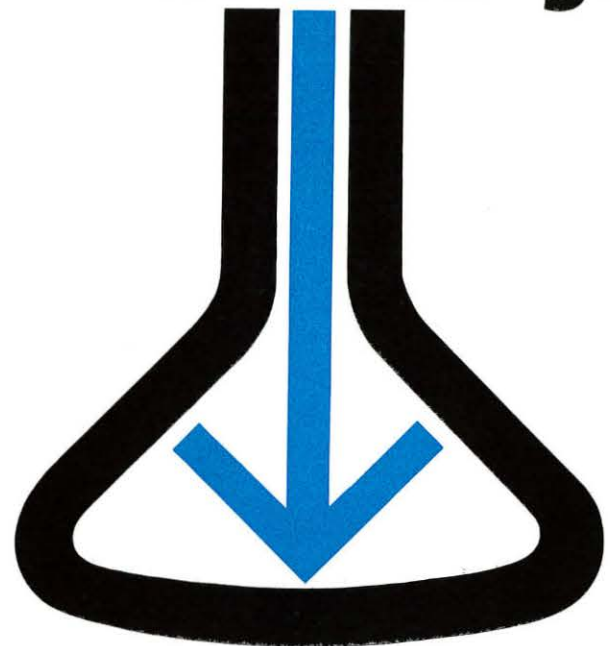
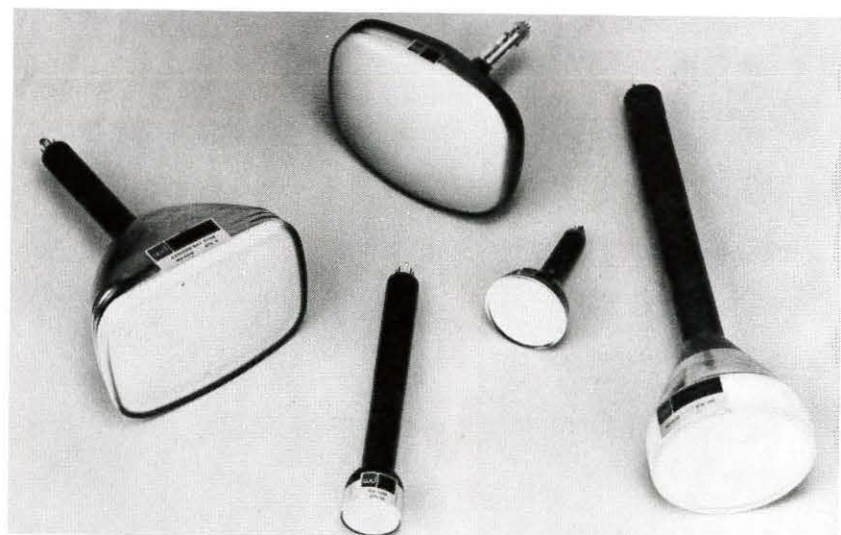

Figure f. Third Version Display

Watkins-Johnson's Laminarflo™ gun



can improve the performance
of your CRT's.



If you have a brightness, resolution or grid drive problem for special display applications, W-J may have the solution.

The Laminarflo gun design concept can be advantageously applied to all types of CRT's, including magnetic deflection-electrostatic focus, magnetic deflection-magnetic focus and electrostatic focus and deflection types.

Get the details on W-J's family of Laminarflo CRT's. Call Watkins-Johnson Applications Engineering at (415) 493-4141 to discuss your specific new tube design or CRT replacement requirements.



Watkins-Johnson—U.S.A.: 3333 Hillview Ave., Palo Alto, CA 94304 • (415) 493-4141 • TWX: 910-373-1253 • Telex: 34-8415 • Cable: WJPLA • 700 Quince Orchard Rd., Gaithersburg, MD 20760 • (301) 948-7550 • TWX: 710-828-0546 • Telex: 89-8402 • Cable: WJCEI • United Kingdom: Shirley Ave., Windsor, Berkshire SL4 5JU, England • Tel: Windsor 69241 • Cable: WJUKW-WINDSOR • Telex: 847578 • West Germany: 8033 Planegg, Muenchenerstr. 17 • Tel: (089) 859-9441 • Cable: WJDBM-Muenchen • Telex: (841) 529401 • Italy: Piazza G. Marconi, 25 00144 Roma-EUR • Tel: 59 45 54 • Cable: WJROM-ROMA • Telex: (843) 60117

Circle #4 on Readers Service Card

remarks and indicated that they didn't feel pressured on the key punch whereas the graphics system was too expensive not to be taken seriously.

In short, our students were afraid of the graphics system. Even though we had designed the system to be simple enough for people with no programming experience to use, students were apprehensive of it. Some

students expressed feelings that they needed to know more circuit analysis coding before using the graphics. This response left us dumbfounded because we had designed the system so that completely the opposite would be true; namely, that users would have to know little about the circuit analysis coding. When asked about this, students said they felt it wasn't costly to learn to code because it was done mostly with pencil and paper

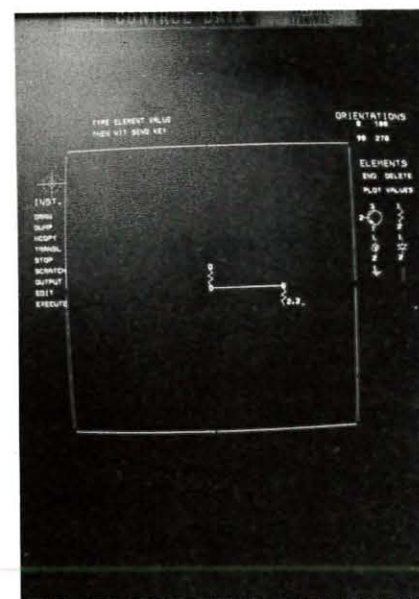

Figure g. Third version display

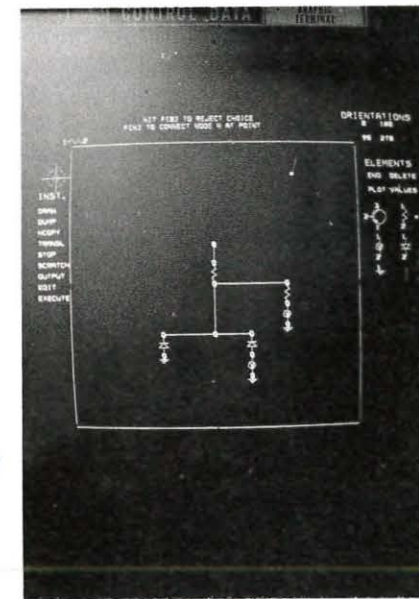

Figure h. Third version display

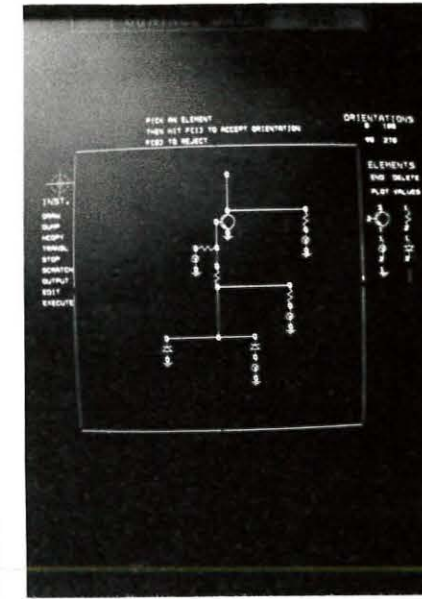

Figure i. Third version display

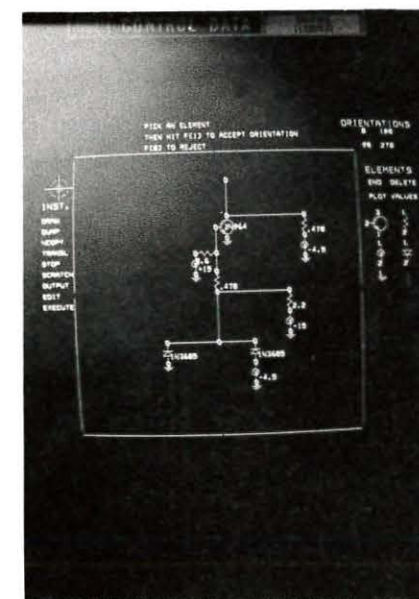

Figure j. Third version display

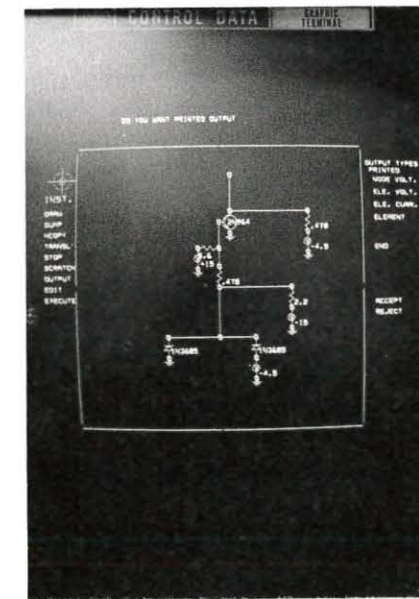

Figure k. Output request display



Figure l. Alphanumeric code editor

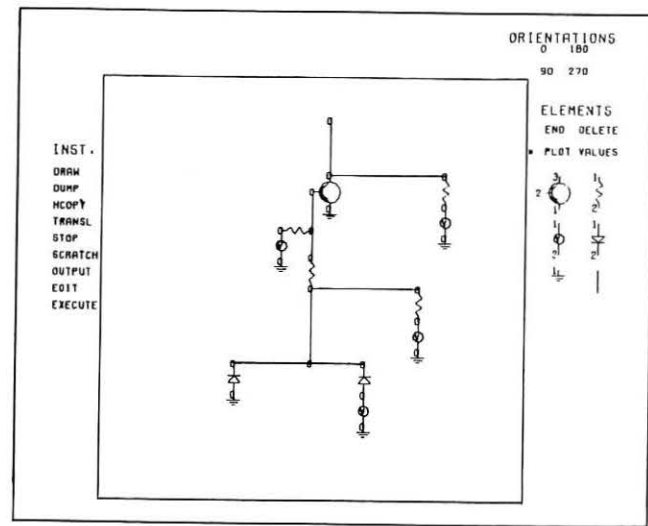

Figure m. Hardcopy of Third Version Display

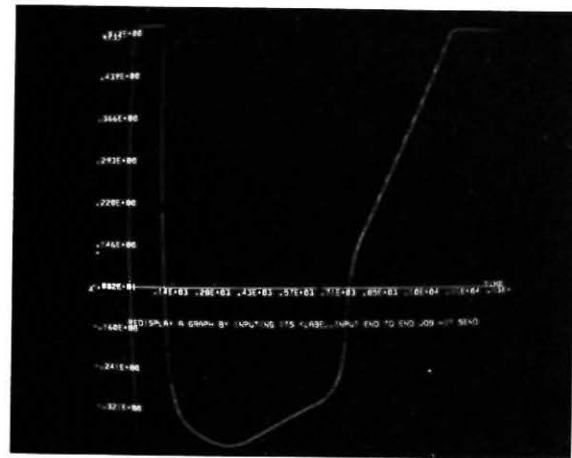

Figure n. Response of Circuit Displayed on Graphics

rather than with complex electronics.

It is interesting to note that the exceptions to these apprehensions about utilizing a computer as a learning tool came from those students that were accustomed to using the computer. In spite of their fears almost all students said they would like the interactive capability, working with the schematic, and the rapid turn-around time to perform an analysis that was afforded by the system — after they became proficient.

It is clear from these comments that successful implementation of graphics, no matter how easy it is to use, is dependent upon giving users the proper orientation and education concerning such factors as cost of operation, slowing down the main frame computer systems, etc. The most important education seems to be in the area of helping students overcome their awe and fear of using a computer.

Experienced User Reaction

The experienced users in our laboratory use the system mainly when they have to meet deadlines or have to work within a limited time frame. It is in these instances, where computer runs can't be done as background against other work, that graphics pays for itself. One user utilizes a technician aid to draw the circuit for him. He then takes over and interacts with the circuit schematic until he receives the desired response. This procedure cuts labor costs and provides the engineer with additional time to pursue creative endeavors.

Since our system is on-line, it is located at the central computing site. Our users have reiterated that even though the site was close by, they felt the system would be used much more if it were in their office. The implication of this is that our on-line

system be replaced by a remote system.

In addition to these comments, experienced users confirmed many of our own findings about the use of graphics as a computer aided design and analysis tool. These were that: (1) graphics act as a natural data manager (many different subcircuits, models, data, and circuits can be handled with ease); (2) the displayed operating instructions remove the necessity of having to review a user's manual to refresh one's ability to use the system; (3) the interactive schematic capability allows a number of successful runs that would have never been equaled in a batch mode in the same amount of time; (4) the schematic representation allows a user to instantaneously know where he left off his analysis or design; and (5) communication between users involved in the analysis is enhanced. Besides these advantages which we expected and had discovered for our-

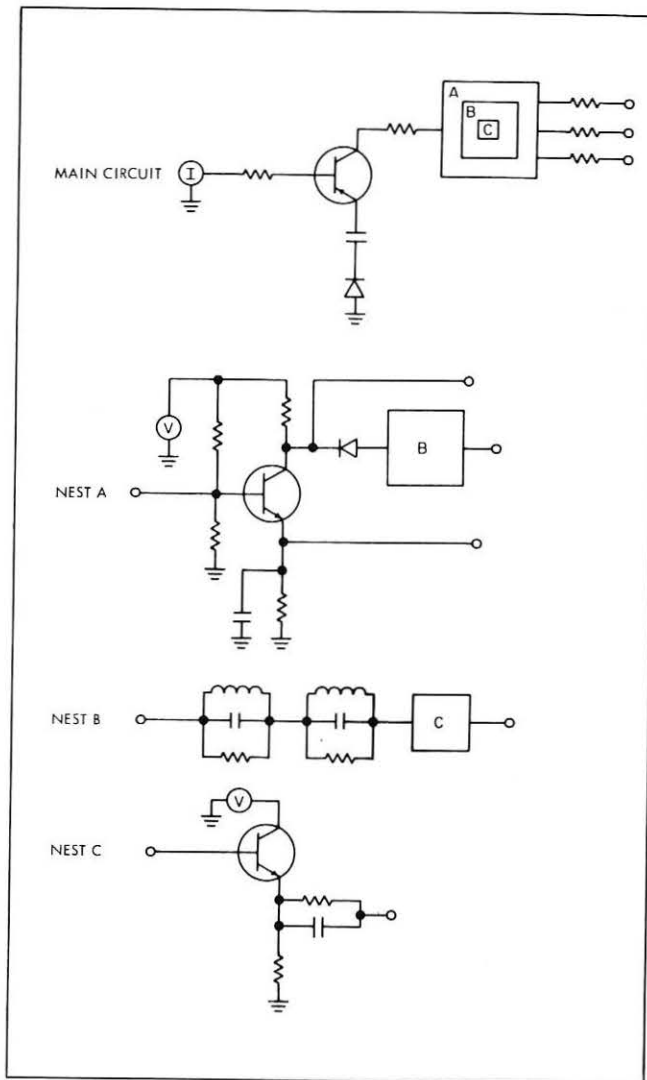

Figure 2. Nesting

selves, the experienced users found an advantage we had overlooked. The hard copy of the displays on the terminal screen could be collated to provide nearly instantaneous reports. In addition to this, the hard copy could be turned into viewgraphs by the standard office copying machines to be used as visual aids for presentations. This short circuited the one to three week lead time of getting material back from the Art Department. It also gave people that smug satisfied feeling when they were able to have on their boss' desk those viewgraphs or progress reports he so desperately needed for tomorrow's briefing an hour or two after his frantic telephone call.

We were surprised to find no one complaining about not having instantaneous response time. (Response times may be as long as 10-15 seconds during peak computer load; however, in most instances it is less than 3 seconds.)

The users tend to use batch input when project funds were low or when their time frames were long enough that the cost of the rapid response didn't warrant its use.

Summary and Conclusions

CANDIG was designed to replace slow and error prone batch card input. It was also designed so that users could become proficient at circuit analysis without having to learn the circuit analysis language. However, when it was taught as part of a course that also used card input, students even though they were turned on to the concept, preferred to learn circuit analysis with cards. The reasons were that they didn't like to make mistakes on a computer system, they felt that they might tie

up the system, and they didn't feel comfortable with their slow learning rate of work on a rapid response system. Experienced users, on the other hand, used the system as it was designed but limited their use because of its costs and location.

It has become obvious to us that we have made an error in believing that the very ease of doing computer aided circuit analysis and design that is provided by the simplistic structure of a graphical language would be sufficient in gaining its acceptance. In point of fact, the truth is that a thorough education process must accompany introduction of graphics to dispel false impressions in such areas as tying up the central computer, high costs, and most important, general feelings of uneasiness with equipment associated with large computers. Part of the education concerning graphics, that must be made known, is that it impacts not only the problem being solved, but also improves the total working environment, e.g. giving the engineer extra time away from drudgery operations, the meeting of deadlines, etc. How this affects costs is not easily demonstrated but nevertheless important. [As an aside but possibly important, it may be a mistake to teach or introduce graphics as part of a course that is also using batch techniques.]

Feedback from our experienced users indicate that if graphics is to be fully utilized, operating costs must be made as low as possible and the system must be available in the local work area. These two factors would indicate that design and analysis graphics systems be driven by small dedicated minicomputers with a time-sharing operating system, rather than embedding the graphics as part of the general computing facility. □

By JEFFREY FRANKLIN
& EDWIN DEAN

See Big Outlays For Air Instruments

Market research study indicates Federal Aviation Administration (FAA) will spend about \$1.25 billion for air traffic control needs over fiscal years 1975-1979, says Frost & Sullivan, market research firm. Firm adds that commercial navigation equipment sales for marine industry also will increase, reflecting increased building of vessels.

Air Traffic control needs will include automation equipment, long range radar, terminal area radar, terminal area automation and other tower equipment; plus flight service stations, instrument landing systems, etc.

Frost & Sullivan sees aircraft production down to about 200 annually, due to energy situation, compared to 625 produced in 1968. Same effect on general aviation (private planes). Market for instrument landing systems is said to be in "holding phase," awaiting final development of microwave landing system.

IEE Canada Rep

Industrial Electronics Engineers (IEE) has named Kaytronics, Ltd., its Canadian sales representative and distributor. Kaytronics has offices in Montreal and in Downsview, Ontario.

Amuneal Plant

Amuneal Manufacturing Corp. moves to a new Philadelphia plant especially designed for the manufacture of shields for magnetic-sensitive cathode ray tubes and electronic components. New facility doubles space at former plant. Production will increase by about 40 percent, says S.M. Kamens, President.



Jeff Franklin; B.S. University of Maryland, Physics, 1963; M.S. Yale University, Biophysics, June 1965; M.Ed., American University, Counseling Psychology, May 1974; currently working on applications of graphics to computer aided design and management information. Previous work has been in the areas of operations research and computer simulation of ship systems.

About the Authors

Edwin Dean received his B.S. in physics in 1963 and his M.S. in mathematics in 1965, both from Virginia Polytechnic Institute. Since 1965 he has been at the Naval Ordnance Laboratory in computer aided design, nuclear weapons effects and general computer applications. Currently he is Chief of the Computer Aided Design and Analysis Branch.



color graphical display system

A method for simplifying and rendering usable in-plant and/or system-control display boards which threaten to become too complicated for practical operation.

By E. YAMAZAKI & K. OHKAWA
Kamakura Works, Electronic Lab.
Kamakura City, Japan

In the control of electric power, steel, and iron plants and in railroad control, the control process becomes complicated and the amount of information increases with the introduction of computers. As a result, the display panel often becomes complicated beyond practical operation.

As one method of solving the problem, we have developed an inexpensive graphical display system with a graphical printer that permits limited graphics using conventional color CRT display techniques. This device can be connected to a mini-computer so as to enable the pictures on the CRT to be handled in blocks. It is applicable to dynamic display and the control of plants of various kinds.

Introduction

Usually in such applications as electrical power stations, steel plants, chemical plants, and transportation, panel board type display systems have been used to monitor the condition of the plants. But, because of the complexity of the plants themselves, and the improvement of information because of expansion of the systems and because of the use of computer control systems, the panel board display system has increasingly become larger and more complex. And, it has become uncomfortable to monitor and control the plants through the conventional panel board display system.

As a result, a demand for a display system which is able to display a selected area of the plant in detail, and which is able to be connected to a computer system easily, has become more and more strong.

To satisfy this demand, we have developed a limited color graphic display system.

The features of this display system are:

- (1) It is possible to display the plants themselves on a conventional commercial color CRT graphically using 1280 (40x32) color picture elements composed of 7x7 dots and color characters. Furthermore, by superimposing two pictures, it is possible to display complex plants on the CRT comfortably.
- (2) By a new logic technique, this system makes it possible to display several different color trendgraphs whose resolution is 1/256 in both the x and y direction and origin is located in the lower left corner of the picture.
- (3) This system provides picture processing software, by which it became possible to handle a picture displayed on the CRT in a block unit. And so, picture generation and picture handling became very easy.

Picture Block Changes

For instance, in the case of a skeleton diagram which describes an electrical power station, one power line which is composed of several picture elements, is handled as one picture block or module. As a result, the color of the picture block is changed, or it starts to blink at once by only one action.

The assignment of the picture block and its registration is accomplished using the CRT display and keyboard with this picture processing software.

- (4) An optional printer is able to be connected to this graphical display system. This graphical printer is a wire dots serial printer which is able to receive the video signal from the CRT display as an input signal and print out the graphic display pattern the same as the picture on the CRT.

Graphical Display System

This graphical display system is different from a conventional graphic display system. As this graphical display system employs conventional commercial color CRT techniques and graphic patterns are composed of color dots, the quality of displayed patterns of this graphical display system is inferior to that of conventional graphic display systems which employs high

resolution analogue techniques and random scanning drawing methods, but the performance is sufficient for the applications mentioned above and the cost is very low relative to conventional graphic display system.

Description of system

The construction of this system is described in Fig. 1. In this system a minicomputer with a disc memory is used to handle the picture on the CRT by picture processing software, and device oriented basic

turn to page 18

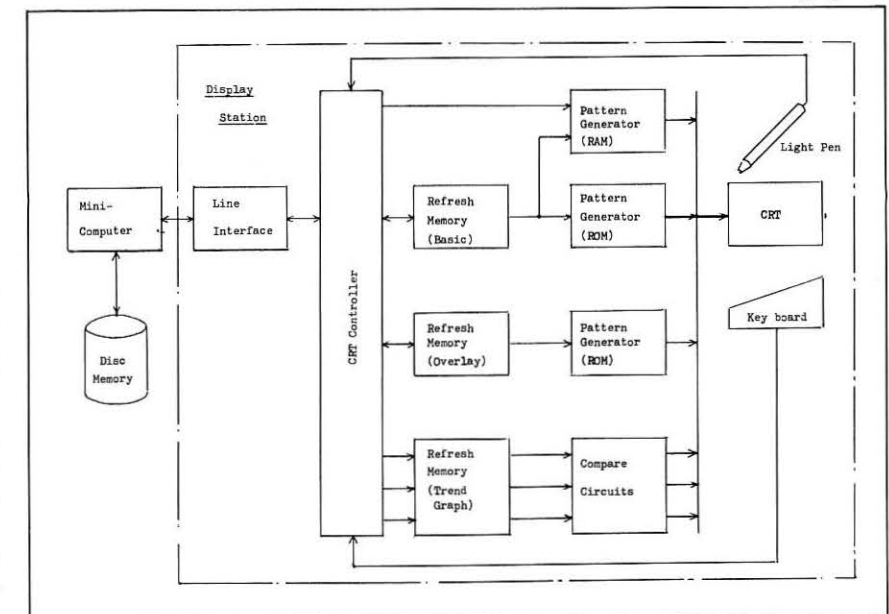

Figure 1. Block diagram of the graphical display

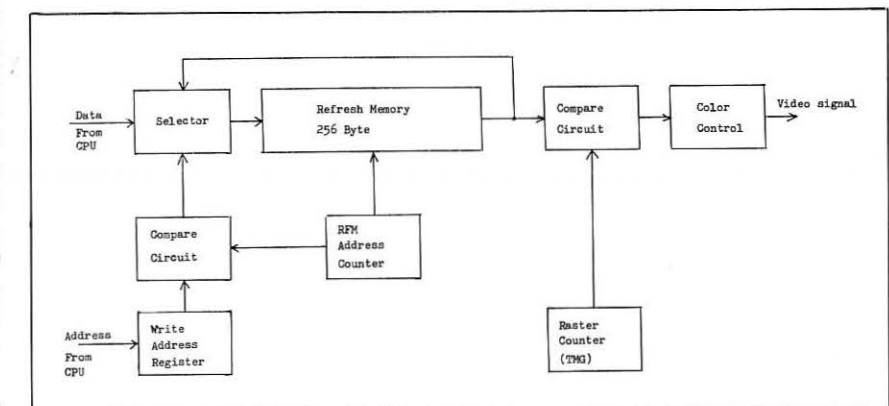

Figure 2. Block diagram of the trend graph circuit

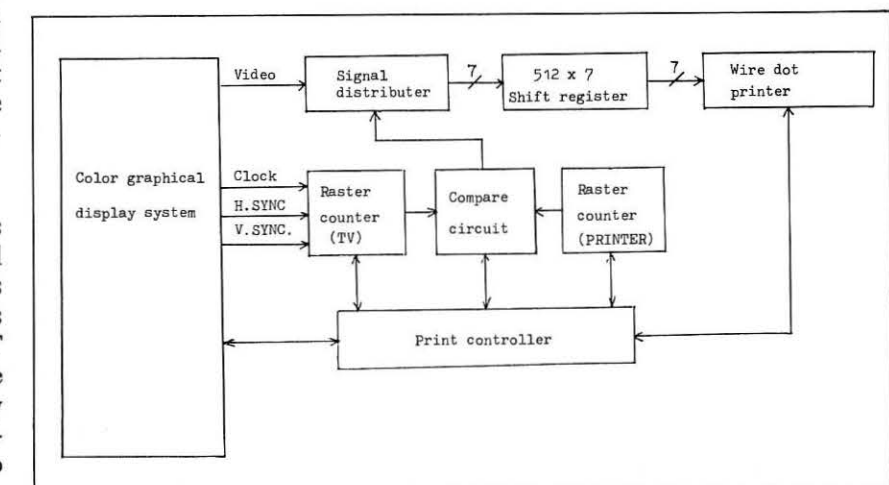

Figure 3. Block diagram of the graphical printer

IEE-LUNA™

NEON TUBE DIGITAL DISPLAYS



- Choice of 3/8", 1/2", or 5/8" high, 7-segment characters
- Sharp, high-contrast display with wide angle (120°) viewing
- Low power — .6 ma @ 130 VDC; cool, wide temperature range operation
- Bright, neon-red, single plane, stable and unobstructed characters
- Rugged, 100,000 hour life construction
- Minimal cost per digit

For your every man/machine interface requirement, IEE has a solution. From "the Olympus of Displays," the world's most diversified selection of display products, technologies, and design expertise, IEE offers you your choice of:

- Multiple Message Displays — rear projection; status indicator/annunciators; mini-CRT's
- Dynamic Message Displays — 64 & 256 character dot matrix panels
- Numeric & A/N Displays — line filament; neon; transilluminated;

LED's (with integrated electronics); liquid crystals; gas discharge; fibre-optics

- Subminiature Lamps — LED & incandescent
- Low Profile Switches — completely sealed, illuminated, custom arrays
- Peripheral Accessories — universal mounting hardware; bezels; interface circuitry
- Customized Products & Multi-Function Systems. Never has so much been available to so many from a single source. Hadn't you better write or call today for your copy of IEE's Product Selector?



the Olympus of displays

Industrial Electronics Engineers, Inc.
7740 Lemona Ave., Van Nuys, Calif. 91405
Phone: (213) 787-0311

European Office: 6707 Schifferstadt, Eichendorff-Allee 19, Germany.

Cutbacks Opposed in Information Funding

The American Society for Information Science (ASIS) opposed a \$3.5 million cutback in the appropriation of the National Science Foundation's Office of Science Information Service (OSIS) in testimony before a Congressional subcommittee recently.

Joshua I. Smith, Executive Director of ASIS, told members of the Subcommittee on Science, Research and Development of the House Committee on Science and Astronautics that, as the major professional society representing information scientists and technologists, ASIS opposed the seeming trend toward diminishing support for scientific and technical information activities.

He stated the ASIS view that there is a distressing lack of an overall national policy regarding such activities. Explaining that exactly such a national policy is required as the United States makes the transition from an industrial to a post-industrial society, Mr. Smith voiced ASIS concern over the drastic cuts to the OSIS budget, especially in view of the marked upswing in support of other NSF programs.

Mr. Smith pointed out that, while nations such as Japan and the Soviet Union are presently embarking on multi-year, multi-billion-dollar programs to develop improved information systems, the United States is consciously neglecting this area. He further stated that the increase in funding for research and development mandated in the 1975 NSF budget was, in effect, buying information. "How then", he asked, "can NSF justify new funds for possibly old or already created information?" While the product of research is information, a lack of NSF-funded information-systems development can mean redundancy and inefficiency in applying this information to society's needs.

GM Buys 'Greyscales' From Albion Center

The British Department of Trade and Industry's Computer-Aided Design Centre (CAD), Cambridge, England, announces the sale of one of its most advanced graphics programs, known as "Greyscales," to General Motors of Warren, Michigan. It is a computer program designed to

← Circle 5 on Readers Service Card

generate realistic half-tone pictures from a 3-dimensional object definition.

The CAD Centre was established four years ago with the prime aim of developing the capability of the computer to integrate the design process and to improve the creative potential of the engineer. "Greyscales" originated from fundamental development work carried out at the Centre.

Among the many areas of application — in architecture, industrial design, civil, mechanical, electrical and chemical engineering — one of particular importance is the checking of 3-dimensional finite element schemes. Finite element errors are very obvious in a shaded picture, and a small investment in producing a few pictures can save a lot of wasted computation in analysis. Principal uses are the assessment of aesthetic properties; checking of design data; illustrations; presentation of results.

A simple command language can be used to request different views and many views can be generated from one object definition. The algorithm used to solve the hidden-surface problem is, in most cases, faster than other methods. Objects can be described with different material reflection properties and materials such as aluminium, steel or even transparent glass, are easily simulated by the program. It is also possible to position a light source to vary the effects of light and shade.

The sale was accomplished by the Center for Scientific Studies, Michigan, USA, a small high technology company specializing in the design, marketing and implementation of hardware and software graphics systems.

Photometer System

EG&G, Inc., Electro-Optics Division announces immediate availability of new low-cost Model 450 Photometer/Radiometer System. Incorporating a single Multiprobe Detector, system provides direct, absolute readings in 4 distinct optical units: watt/cm², foot-candle, foot lambert, and lux. Direct reading concept is said to eliminate need of post-measurement calculations thereby significantly simplifying light-measurement task. Instrument contains 3 1/2-digit panel meter with dynamic range of six full-scale decades.

Circle 12 on Readers Service Card

Circle 5 on Readers Service Card →

IEE-AURORA™

INCANDESCENT FLATPACK DIGITAL DISPLAYS

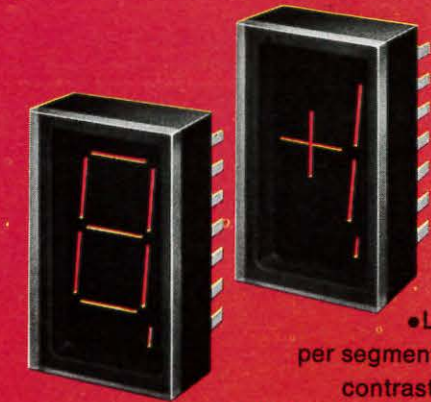

- Choice of 1/2" or 5/8" high, 7 segment characters
- 4,500 F/L of "morning dawn" brightness
- Low power — 15 MA per segment @ 5 VDC
- Sharp contrast and excellent, 120° readability in high ambient/sun lighting
- Convenient slim profile, standard DIP packaging
- 100,000 Hours average life

From the very beginnings of information display, IEE has been a leader in the innovative design, successful introduction, reliable manufacture, condensed packaging, and effective application of high quality, display devices and integrated systems for commercial, industrial and military use. Based on two decades of experience, and a dedication to quality, IEE today offers: • the world's most diversified selection of display products • the design, human

factors, and systems integration expertise to fulfill your most sophisticated requirements • the pricing, product availability, and productive capacity to meet your most demanding schedules • and the ingenuity and sincere desire to help solve your most complex display problems. Information Display is



OUR business; why not contact the experts for YOUR solutions? Call or write today for information regarding introductory offers on prototype evaluation quantities of many of IEE's display products

the Olympus of displays

Industrial Electronics Engineers, Inc.
7740 Lemona Ave., Van Nuys, Calif. 91405
Phone: (213) 787-0311

European Office: 6707 Schifferstadt, Eichendorff-Allee 19, Germany.



Photo 1. Graphical display system

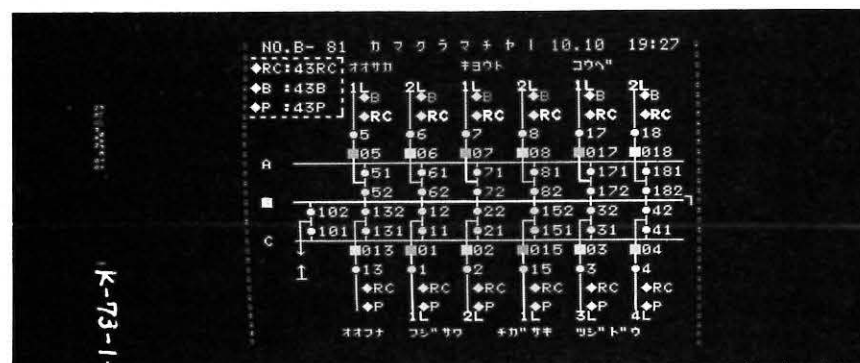

Photo 2. Skeleton diagram displayed on the CRT

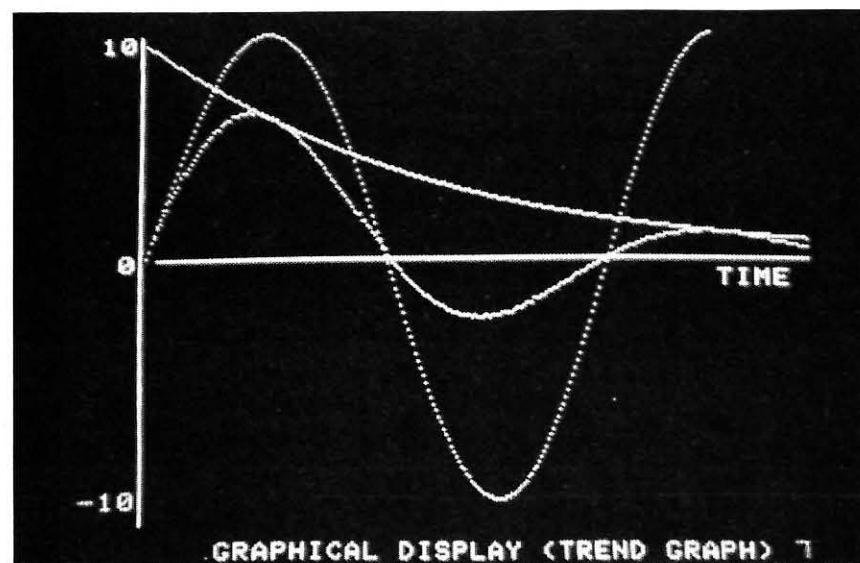

Photo 3. Trend graphs displayed on the CRT

continued from page 15

operations, for instance edit operations, are performed at the display station. The display station is composed of line interface, CRT controller, refresh memories, pattern generators, and CRT with keyboard and light pen.

The construction of this display station is similar to a conventional raster-scan type character display system, but is different from these systems in that this graphical display system has three types of refresh memory and has three types of pattern generation.

Two of the refresh memories store coded data which correspond to pattern or character, and each of the refresh memories can store a maximum of 1280 (40x32) data points. One of them constructs a basic picture and the other constructs an overlay picture.

The third refresh memory is for trend graphs, where the contents stored in memory, are different from the other refresh memories.

The refresh memory for trend graphs is constructed of eight, 256 bit, parallel shift registers. In this refresh memory, 256 byte binary data are stored and displayed on the CRT as one trend graph composed of 256 dots.

Pattern Generator Categories

Pattern generators are classified into two categories. One of them is for the conventional patterns like picture elements and characters. A picture element is composed of 7x7 dots and a character is composed of 5x7 dots.

Further, the conventional pattern generator is divided into a ROM type and a RAM type. The ROM type pattern generator stores fixed graphic patterns and character patterns, and the RAM type pattern generator stores variable graphic patterns which are rewritten by the CRT controller.

Another pattern generator is one for trend graphs which is composed of a comparison circuit between contents of the trend graph refresh memory and the raster scan counter.

This display system has three pairs of trend graph refresh memories and comparison circuits and so it is possible to display three different trend graphs.

The output from these pattern

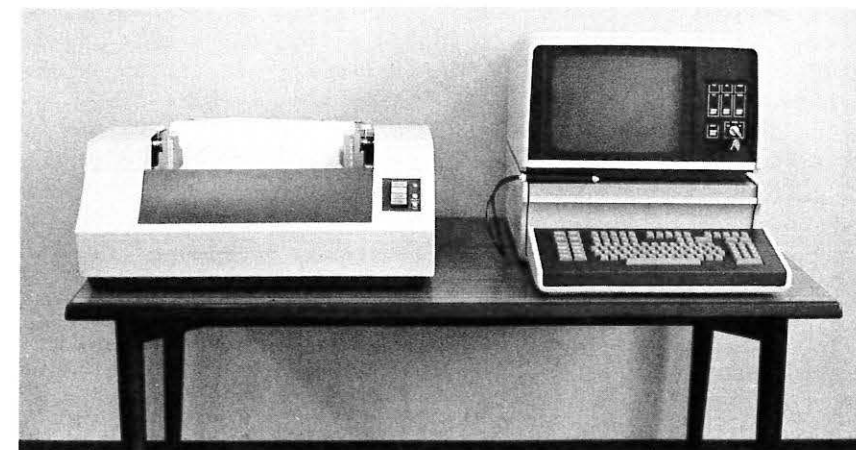

Photo 4. Graphical printer attached to graphical display

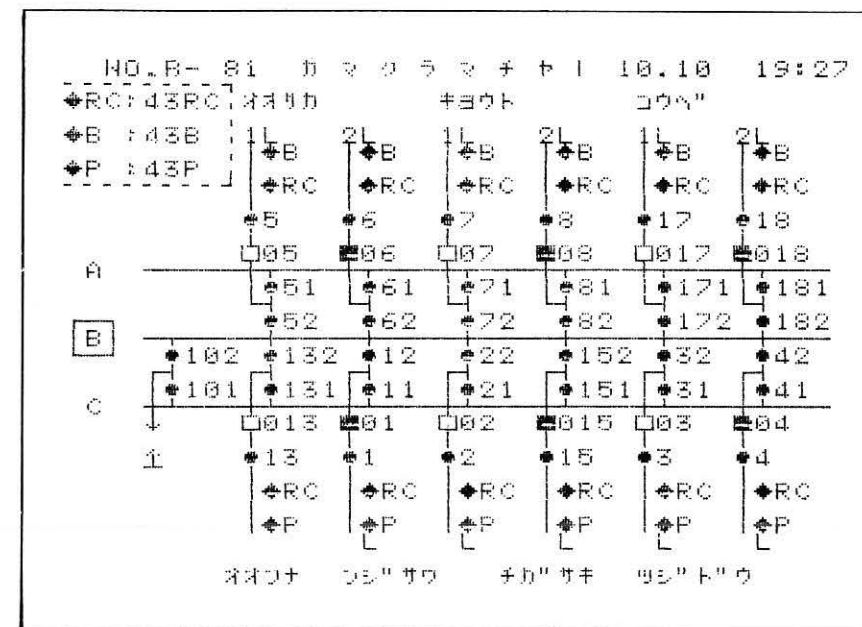

Photo 5. Skeleton diagram printed out by graphical printer

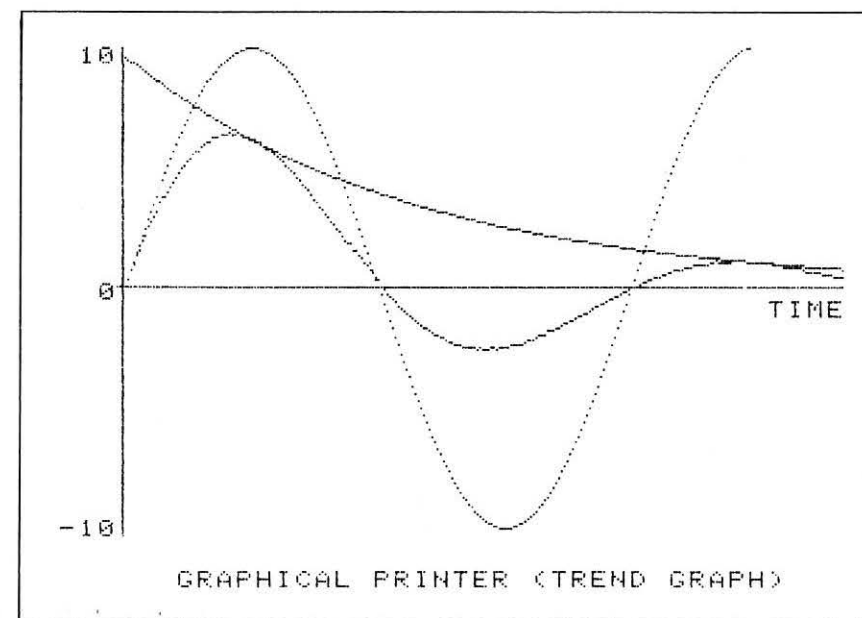

Photo 6. Trend graph printed out by graphical printer

By E. YAMAZAKI
& K. OHKAWA

generators are serialized respectively, put through a logical "or" circuit, and sent to the CRT to display pictures, characters and trend graphs.

Photo 1 shows the display station of this system and photo 2 shows the skeleton diagram displayed on the CRT.

Trend Graph

The origin of trend graphs can be located in the lower left corner of display area on the CRT.

Fig. 2 shows the block diagram of the trend graph circuit.

In the refresh memory, 256 byte data are stored and refreshed cyclically once per raster, synchronizing to the horizontal raster scan. Each output data from the refresh memory during refresh is compared with the contents of the raster counter which indicates the Y coordinate value.

When the output data corresponds to the Y coordinate value, one dot on the CRT is brightened.

In this manner, the 256 byte data are compared, and 256 dots are brightened on the CRT in every frame.

New data for the trend graph from a computer, are written in the memory, while circulating the refresh memory.

The address to be written in the refresh memory is stored in the write address register and incremented in every write operation. The recirculating data position of the refresh memory is indicated by the refresh memory address counter. These two address data are compared in the comparison logic. When the RFM address counter corresponds to the content of the write address register, new data from the computer is written in the refresh memory.

Picture Handling

In this graphical system, three of these trend graph blocks are provided. So, three different color trend graphs can be displayed on the CRT.

Photo 3 shows the trend graphs displayed on the CRT.

In this system, to make it easy

to generate and handle the pictures, picture processing software is provided in a minicomputer.

This software is composed of three subroutine groups and two support programs. They are as follows:

- (1) Subroutines for picture generation
- (2) Subroutine for picture handling
- (3) Subroutine for common operation for Picture generation and Handling
- (4) Pattern generator (support program)
- (5) Picture generator (support program)

In this section we will present the picture generator operation and subroutines for picture handling.

To handle the picture in block units, we must assign the desired picture elements on the CRT as one picture block.

This assignment is accomplished by checking the difference between original picture data stored in minicomputer memory and picture data displayed on the CRT which is rewritten partially using the keyboard to assign picture blocks.

Storage of Picture Blocks

These assigned picture blocks are named and stored in the data area

in the minicomputer memory one by one, and at last all of these blocks are stored in disk memory.

The pictures stored in block units are handled by picture handling subroutines as follows:

1. Update Block
Only the text of the old picture block are updated by new data.
2. Position Control
Any picture block can be moved in X, Y directions in steps of one picture element.
3. Color Control
The color of the picture block can be changed to any of seven colors.
4. Blink Control
It is possible to set the picture block into a blinking state or to stop it from blinking.
5. Update Block for Trend Graph
Old data of trend graph are all rewritten by new data.
6. Extended Block for Trend Graph
New trend graph data are added to old data continuously and the graph extended.
7. Color Control for Trend Graph
The color of a trend graph can be assigned to any of seven colors.
8. Display Control for Trend Graph
It can be controlled to display or not display any of the three trend graphs.
9. Horizontal/Vertical Graph Update
Horizontal or vertical bar graphs can be displayed, which have a resolution of 1/280 in the X

direction and 1/224 in the Y direction and which have a width equal to one picture element (equal to 7 dots).

These graphs can be updated by this subroutine by giving only the value indicating the length of the bar graph.

10. Request Attention
If the picture block which is assigned by light pen is registered as a light pen detectable picture block, this subroutine sends the picture block identifier to the user's program. If not registered, it sends a zero to the user's program.
The operation following it is decided by the user's program.
Using these subroutines, we can handle the picture easily and dynamically.

Hard Copy

As mentioned above, this graphical printer has a hard copy printer which employs a modified wire dot printer.

A conventional wire dot printer has a seven wire stylus arranged vertically in the printer head, and shifting the printer head horizontally and striking the printer paper by selectively activated wire styluses, it prints out any kind of characters.

But these character printers have a line spacing which is uncomfortable for graphical printer. So, we modified the paper feed mechanism

so as not to have the line space.

The block diagram of the graphical printer is shown in Fig. 3, and the graphical printer with the display is shown in Photo. 4

The video signal from the graphical display is stored in a shift register type memory in the printer controller. This memory is composed of seven shift registers of 512 bits.

Since each shift register stores the video signal displayed in one raster time, this memory stores seven rasters of video signal.

When the memory is filled by video signals, the printer controller turn into the printer mode. Then the data stored in the memory are read out synchronized to the printer timing, and supplied to the solenoids to activate the wire styluses in the printer head.

After that the next seven rasters of video signal are stored in the memory, and printed out to the printer.

The one dot printing rate of this wire dot printer is 1 msec, the number of elements in one raster of video signal is 280, the time for fly back of printer head is about 150m sec and there are 35 lines in the display, so it takes about 15 sec. to print out a picture displayed on the CRT.

Using this graphical printer, we can get a hard copy of not only characters but also graphical patterns displayed on the graphical display.

Photos 5 and Photo 6 show the printed out results.

Conclusion

This graphical display system can display and control the state of many kinds of plants dynamically supported by picture processing software and optional instruments such as a light pen and a keyboard. This system is just like a window through which we can observe many kind of plants.

Already we applied this system to power plants, railroad control systems, ship controls, etc.; moreover we expect it to be used in other applications which are able to utilize its characteristics. ■

References

1. Claude A. Wiatrowski; A color-Television Graph Platter for Digital Computers. Computer Design, April pp 45-48, 1970

2. Klaus Bindewald and Hans Kurner; Graphical Colour Display Terminal 300 for Process Computers, Siemens Review pp 14-18 XL No. 1 1973
3. K. Ohkawa, O. Watanabe, T. Den and I. Ogawa; Stand Alone Type Color Character Display System, Mitsubishi Denki Engineer, pp 16-20 No. 35 Dec. 1972

'Get Involved,' DPMA Tells Members

A set of "guidelines for government and public liaison" has been published to assist members of Data Processing Management Association (DPMA) in responding to social issues regarding information processing.

The guidelines encourage the involvement of all members in assuming their responsibilities to help solve information processing-related problems in government, the schools and the local community, said Merton R. Walker, CPCU, CDP. Walker is a DPMA international vice president and chairman of its committee on association liaison and international

affairs which prepared the guidelines.

"We must fulfill our responsibility to society and speak up when our profession is the target of those who degrade our ability to respond to the needs of today's society," said Walker who is assistant vice president, management information services, State Farm Fire & Casualty Co., Bloomington, Ill.

"The guidelines stress that every DPMA member should be notified of the Association's plan to speak on issues which we feel need to be considered by people with our expertise and background," said Walker.

For information concerning subscriptions to the SID Journal, please contact Blackwell Publishing Co. directly, 1605 Cahuenga Blvd., Los Angeles, Calif. 90028.

About the Authors



Ezio Yamazaki holds B.S. and M.S. degrees in electrical engineering from Tohoku University, Japan, and a Ph.D. from Osaka University. He joined the central research laboratories, Mitsubishi Electric Corp. in 1959. In 1968 he was transferred to the computer group, electric laboratory, where he is working on the development of computer peripherals and terminals. He is a member of the IEEE U.S.A., the IEE Japan and the SICE Japan.



Kiyoto Ohkawa holds a B.E. degree in precision engineering from the University of Osaka, Japan. From 1961 to 1968 he worked with the instrument group of central research laboratory, Mitsubishi Electric Corp., Hyogo, Japan. Since 1968 he has been in the computer group of electronics laboratory, Kamakura Works, Mitsubishi Electric Corp., Kamakura, Japan, and has been concerned with development of computer peripherals and terminals. Recently, he has been engaged in development of new remote terminal system. He is a member of the Institute of Electronics and Communication Engineers of Japan.

Kaiser Can Help Right Now.

Radar pictures on a

TV screen: Kaiser introduces a solid state Digital Signal Converter (DSC) that displays Rho Theta radar data on standard TV monitors. Our DSC offers many advantages to marine, airborne and ground radar systems—360° and sector PPI, depressed center, 90° PPI offset and spotlight modes. Variable persistence and frame freeze, too.

A mini-computer processes and stores radar, sonar, IR, LLLTV or other sensor data and lets you program courses and targets and predict probable areas of danger. Solid state circuitry means increased reliability and maintainability.

Call Kaiser Marketing at 415-493-3320 and request a demonstration—your place or ours.

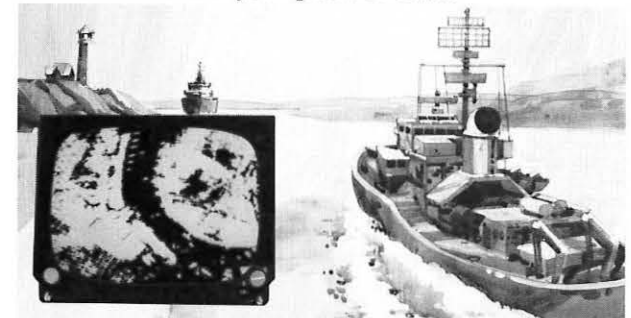

KAISER
AEROSPACE &
ELECTRONICS

1681 Page Mill Road, Palo Alto, California 94306, A subsidiary of Kaiser Industries Corporation.

Circle #3 on Readers Service Card

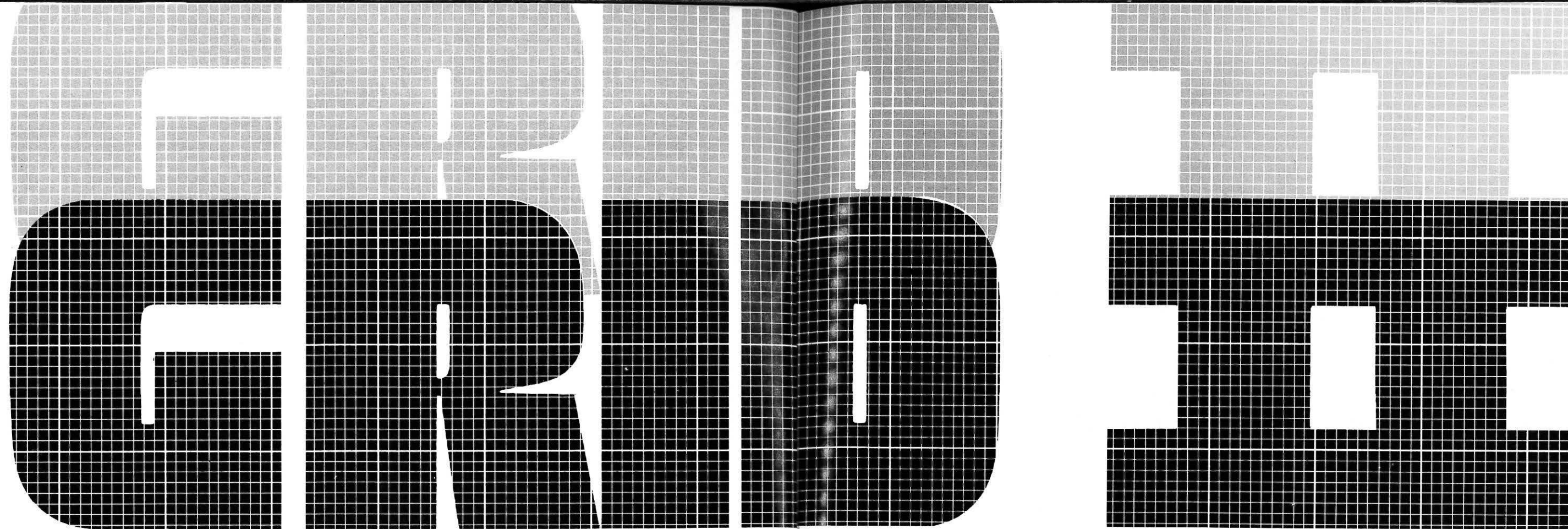

A minicomputer implementation of an interactive graphic system for the purpose of creation, modification, storage, retrieval, and hard copy of alpha-numeric and geometric data.

By RICHARD PEDERSON
McDonnell Douglas Automation Company
Long Beach, California

McDonnell Douglas Automation Company recently implemented GRID II, an interactive graphic diagraming system. It is the successor to GRID, a production system since 1968. GRID has been used primarily to create, modify, store, retrieve, and hard copy aircraft electrical drawings; but may be utilized for other purposes where there is a requirement for construction or modification of graphic forms.

Grid History - DAC Tried It and Like It

In 1968 McDonnell Douglas implemented GRID on a XDS 9300 and six Tasker Industries 21 inch round refresh display devices. The software was developed by McDonnell Douglas specifically for this hardware configuration. The system generated electronic schematics for the Manned Orbital Laboratory. Upon cancellation of the Orbital Laboratory, Douglas Aircraft Company was made beneficiary of the system. The DC-10 aircraft wiring diagrams were created, stored, modified, and hard copied via the GRID system. As time passed,

the hardware became increasingly less reliable and maintenance more costly, but GRID as a production drawing system had gained a high respect. A specification for GRID II was drafted. The primary considerations in this draft were draftsman operating efficiencies, corporate compatibilities, drawing storage and control, and

hardware interchangeability. In October 1972, MCAUTO began development of a replacement system which was to be designed from a specification based on improving an already successful system. Following is a description of the results of this development - GRID II - implemented in February 1974.

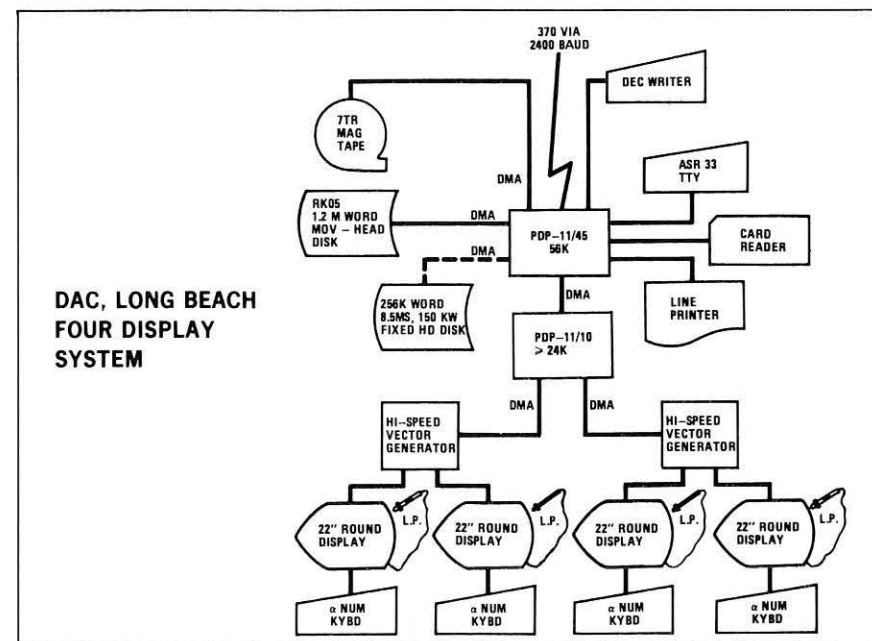

Figure 1.

Grid II Hardware - Mini Computer Maxi Task

Figure 1 shows the hardware configuration of the GRID II production system. A functional description is as follows:

- PDP-11/45 - Primary processor which has total control and application execution responsibility.
- PDP-11/10 - Display control and refresh.
- DISPLAY DEVICE - Vector General Inc. 22 inch refresh display to which drawing geometry is projected.
- FIXED HEAD DISK - Contains executable load modules, currently active drawings, and pre-defined geometric forms.
- MOVING HEAD DISK - Contains a limited local drawing file.
- MAGNETIC TAPE - Receives drawing data in plotter format. This tape is then carried to an off line plotter.
- 370 VIA 2400 BAUD - Communication to remote drawing files.

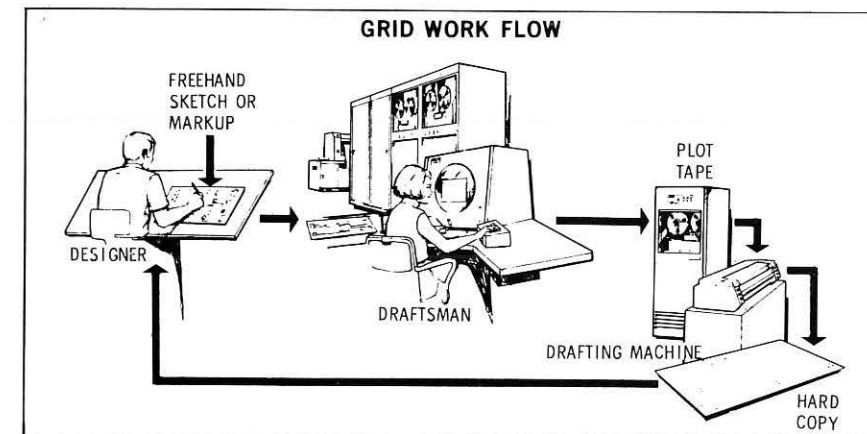

Figure 2.

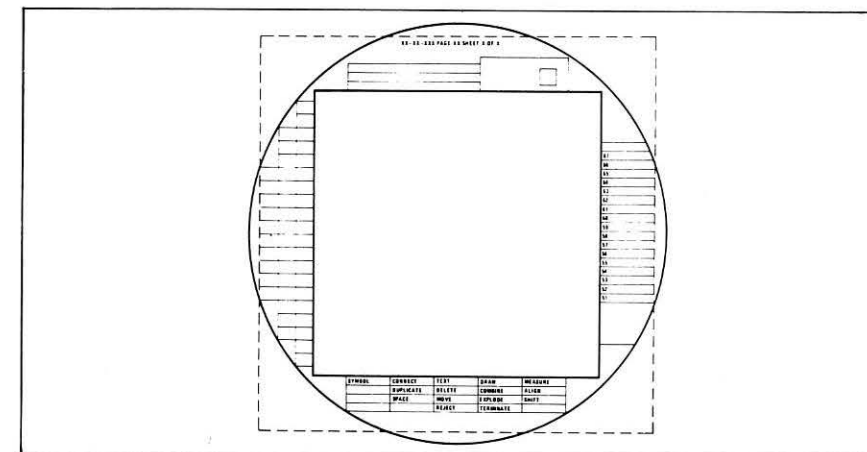

Figure 3.

By RICHARD PEDERSON

- DECWRITER – User terminal for drawing and production control.
- LINE PRINTER – Status and report output.
- TELETYPE AND CARD READER – Development fixtures only - not required for production.

Grid II Software - Modular for Flexibility

GRID II was forced by hardware obsolescence and lack of adaptability to other corporate graphic requirements, hence, the primary design criteria for GRID II are hardware independence and application flexibility. Maximum hardware independence was achieved primarily through modular packaging of software and by utilization of Fortran as the source programming language. Because of the specialized requirements of the GRID II system, existing sys-

tem software was not adequate. Therefore, all software was developed by MCAUTO. Following is a list of sub-systems:

Development Subsystems

- MULTI-TASK OPERATING SYSTEM – Allows simultaneous graphic interaction via the display devices as well as background processing of sub-tasks.
- COMPILER – A FORTRAN, MAD, assembly language combination translator to allow programming versatility and to generate more economical (both size and speed) machine instruction than was available.
- LINKER – LOADER – To create load modules of object code generated by the compiler.
- TEXT EDITOR AND FILE MANAGEMENT – To control and manipulate system files.

Production Subsystems

- DISPLAY INTERFACE – To

convert drawing geometry model data to VECTOR GENERAL display format.

- ITEM CREATION AND DISPLAY – Allows formatting of data to the specialized structure of the data base.
- GRAPHIC DYNAMICS – Allows creation, deletion, movement, grouping, etc. of graphic forms.
- GRID II APPLICATION – This module uses the programs in the previous two modules to control the interaction between man and the computer.
- SYMBOL GENERATOR – To create and store geometric forms which become immediately selectable within the GRID II library of pre-defined symbols.
- ADMINISTRATIVE TERMINAL – Allows administration of the drawing system. (Runs in background)
- HARD COPY – Converts drawing model data to a plotter

format and writes it to magnetic tape. (Runs in background)

- TELEPROCESSING – To store and retrieve drawings from remote IBM-370. (Runs in background)

Grid II Operation – No T-Squares or Templates

The GRID II production manpower includes a production administrator, a coordinator-inspector, and one draftsman for each display monitor. The production administrator uses the administrative terminal subsystem to store, retrieve, create, duplicate, and reidentify drawings. He controls drawing status and generates commands for various reports and plot tapes. He operates the computer and plotters.

The coordinator-inspector receives designer inputs, assigns work to draftsmen and assures accurate hard copy output and distribution.

The draftsmen interact with the computer at their display stations to generate the required drawings. Figure 3 shows the display format which a draftsman views as he works. The interaction is generally mode orientated. The main menu (bottom of screen) is displayed at all times and the mode may be changed at any time by selecting the desired menu item with the light pen. The selection of SYMBOL causes a display of a library of pre-defined electrical components in geometric form to be displayed in miniature within the rectangles at the left of the screen. The top left of the display is reserved for messages which guide the draftsman. At all times the draftsman knows available options via this prompt area. The upper right of the screen shows two rectangles. The largest is a scaled representation of the entire drawing sheet. The smaller is a window within the sheet which is currently being viewed within the work area of the

screen. The right side of the screen is reserved for selectable options which are made available when a particular main menu function is selected. Following is a brief description of each main menu function.

- SYMBOL – Allows selection and positioning of pre-defined geometric forms.
- CONNECT – This mode generates several alternative methods of interconnection of drawing components.
- TEXT – Gives the draftsman the capability to key in alphanumeric data to the drawing in various sizes, orientations, and start positions.
- DRAW – Allows line generation via several methods of data input, one of which is a direct light pen pick within the work area.
- MEASURE – Gives the draftsman the capability to interrogate the drawing measurements of various types.
- DUPLICATE – An item or group of items may be duplicated once or many times and then repositioned.
- DELETE – Items or groups of items may be deleted from the drawing when this mode is entered.
- COMBINE – Lets the draftsman create a set of items which may be operated on as a group.
- ALIGN – Generates horizontal or vertical alignment of one or more drawing items.
- SPACE – Allows convenient spacing options of displayed items.
- MOVE – Gives the draftsman the capability to move an item or group of items via several input forms.
- EXPLODE – Reverses the combine operation.

By RICHARD PEDERSON

- SHIFT – Allows movement of the current view window (upper right of screen) within the drawing sheet. Also allows change of size of the view window up to the actual size of the drawing sheet.
- REJECT – Selection of this function cancels the last operation performed by the draftsman.
- TERMINATE – Allows orderly drawing save and termination of work on the current drawing.

Figure 4 shows a reduced image of the final hard copy of a typical Douglas Aircraft drawing. This drawing is normally plotted at 30 inches by 40 inches.

Grid II Productivity – Better Than Grid

Using GRID, one draftsman could produce the work of 4 to 6 draftsmen using conventional methods. GRID II, because of its upgrading, is expected to surpass this productivity. GRID saved Douglas Aircraft an established 1.9 million dollars during a four year period of DC-10 wire diagram drawing output. Because of reduced hardware costs and an estimated higher productivity, it is expected that GRID II will allow even greater savings in what was previously a very significant cost reduction.

Because of the flexibility built into the GRID II design, data within the stored drawings may be extracted to form various necessary reports. In addition, other applications may be implemented which utilize the GRID II structure. Areas such as mechanical and architectural drafting, facility management, geometric analysis, and various 3-D applications may be the future for GRID II. □

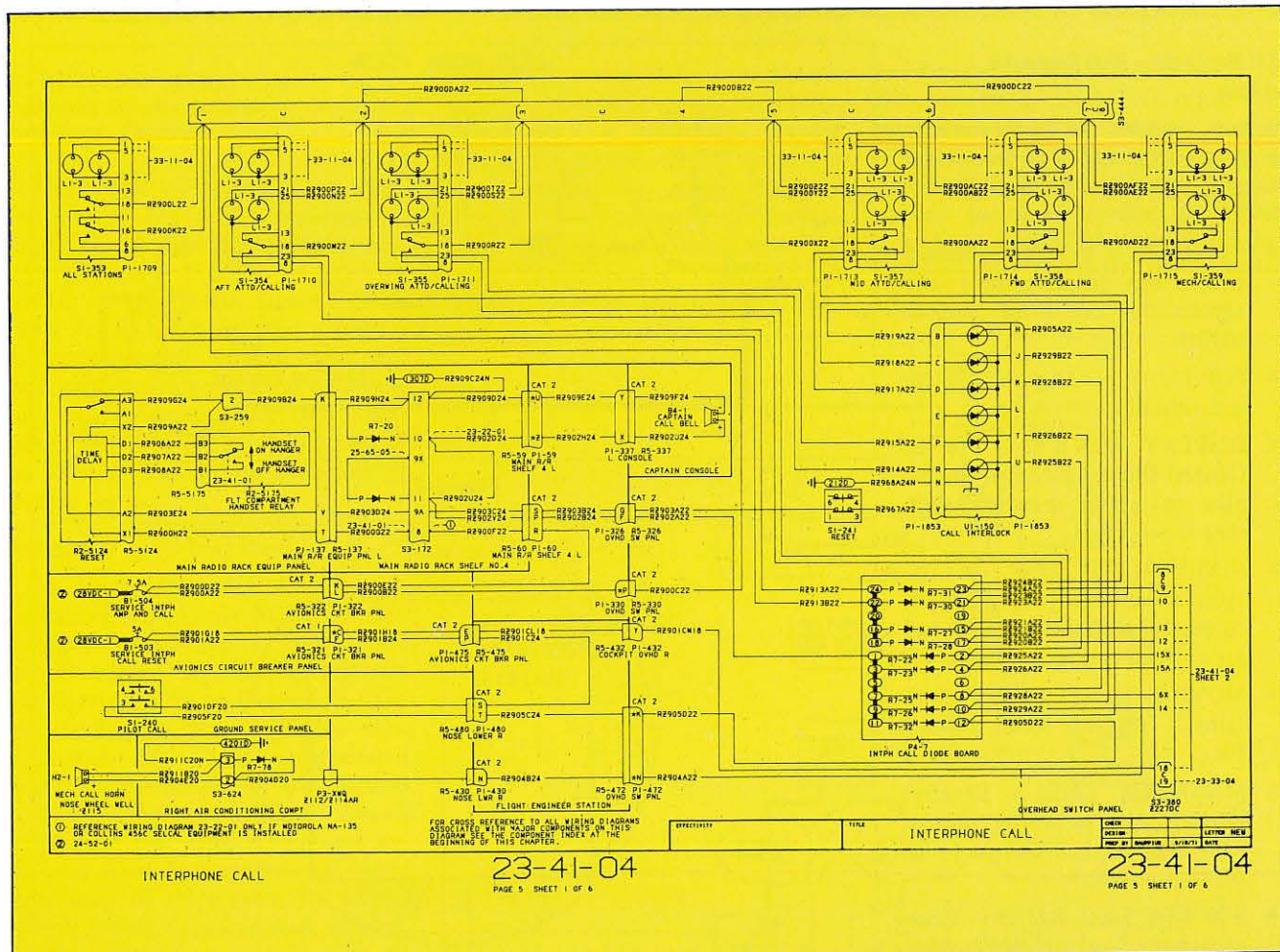

Figure 4.



about the author

Richard O. Pederson is a staff member of the Systems Programming Group at McDonnell Douglas Automation Company, Long Beach, California. He is a man-machine communication specialist who has developed several large interactive graphic systems which primarily involved manufacturing processes, such as numerical control, circuit masks, part detailing and schematics. He has also developed compilers which are hybrids of strengths of algorithmic languages. Mr. Pederson is a graduate of St. Cloud State College, Minnesota and holds an M.S. from West Coast University, Los Angeles.

'Finite Element' Use For Savings

General Motors Research Laboratories structural engineers are sharpening a new mathematical tool that automobile designers can use to cut weight without sacrificing strength or safety.

New time and cost saving methods using finite element analysis were discussed by Research engineers at the International Conference on Vehicle Structural Mechanics in Detroit, March 26-28.

The finite element method consists of mathematically dividing an automobile frame or body into small triangular or rectangular plates or beams. The engineer can then use the computer to check a vehicle to determine if it has the strength and stiffness to resist operational loads.

While finite elements are being used in design of buildings, bridges and aircraft, its most recent application comes in the analysis of the

complex automobile structure. By enabling designers to save weight in structures, the finite element method has potential for increasing fuel economy in future automobiles.

Seven GM Research engineers and mathematicians gave papers at the conference on various aspects of finite element analysis. A summary of their findings includes:

- a new procedure that allows the engineer to use analysis results generated for one vehicle configuration to evaluate the effect of a change on that vehicle. Cost savings are estimated to run 30 times the original investment in computer time.
- a special technique has been developed to connect very detailed sections of an automotive frame to sections that require less definition.
- a mathematical technique for describing the effects of irregular terrain (bumps and holes in pavement) on an automotive structure has been developed. It was adapted from a method used in aerospace engineering to evaluate the effects of air turbulence on aircraft design.
- using interactive graphics to divide into plates and beams the complex automotive geometry displayed on a cathode ray tube has helped to produce low error data at a speed not possible when doing the same procedure manually.
- finite element problems that are too large for the computer can be condensed to a manageable size without generating large data errors.
- FEM can be used to predict the deformation of sheet metal shells where the load is concentrated at one point on the structure.
- FEM can also be used to estimate the critical point at which automotive rubber components begin to fail.

Rechtin of H-P

Eberhardt Rechtin has been named chief engineer of Hewlett-Packard Company, it was announced today by David Packard, board chairman. Dr. Rechtin previously had been HP's manager of telecommunications.

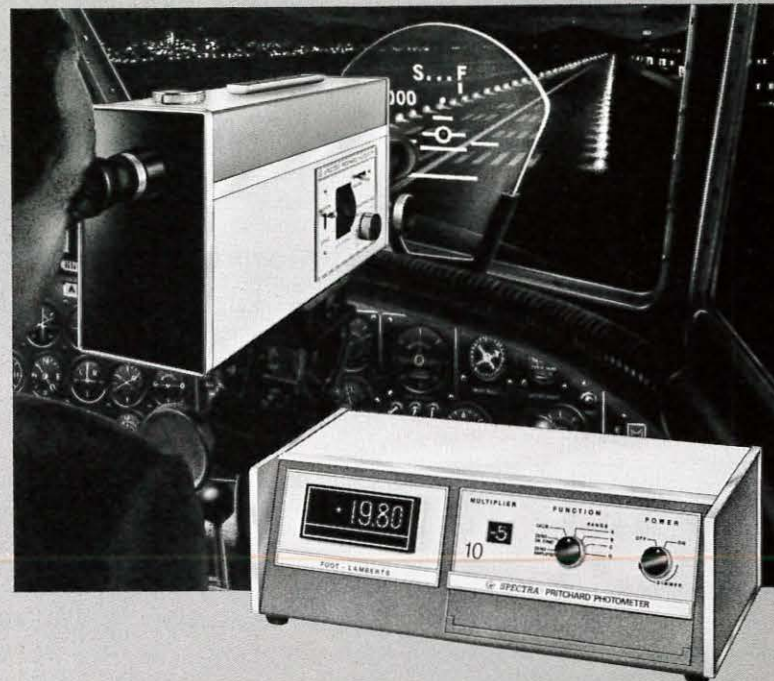

Set your sights on a Spectra® 1980 Pritchard™ Photometer

SPECTRA® 1980 — the only precision photometer with Auto-Comp™ which permits AUTOMATIC readout of light in DIRECT UNITS, regardless of filter, aperture or range setting selected.

The HIGH ACCURACY SPECTRA® 1980 is totally free of polarization error, and is sensitive down to 10^{-3} foot lamberts full-scale.

The VERSATILE SPECTRA® 1980 functions as either a micro-photometer or telephotometer — measuring luminance, illuminance, radiance, color temperature, tristimulus color, etc. — from 0.001 inches to infinity. Five easily selectable measuring fields provide angular coverage from 2 arc-minutes to 3.2 degrees.

PHOTO RESEARCH
The light measurement people

3000 No. Hollywood Way, Burbank, California 91505

(213) 849-6017 • Telex 66-2429

A Division of KOLLMORGEN Corporation

Circle 7 on Readers Service Card

NEW PRODUCTS

Photo Research Meter



New addition to its line of industrial photometers is announced by Photo Research, Inc., division of Kollmorgen Corp., the SPECTRA[®] illumination engineering safety meter.

Instrument reads out directly in foot candles (range 0 to 30,000) to enable lighting engineers as well as building supervisory personnel to selectively reduce illumination levels, "thus complying with local energy cuts while still maintaining adequate illumination levels according to ANSI and OSHA standards."

Circle 101 on Readers Service Card

Indicator Light

The Sloan Company announces immediate availability of unique new modular LED indicator. The P175 "Savage" unit offers designers nylon-bodies unit that snap-mounts in quarter inch hole on 3/8 inch centers, or PC board mounts, vertical or horizontal. Snap-on domed or flat lenses with fresnel rings are offered in colors and allow quick replacement of Sloan-furnished bright, 180° viewing LED's or those of any other leading manufacturer. The P175 "Savage" is available in 2 to 28 volt versions.

Circle 102 on Readers Service Card

Hispeed Interface Card

High-speed serial interface that links together HP 2100 computers has been developed, says Hewlett-Packard Company's data system division. Hardwired interface card, designated HP 12889A, enables asynchronous data transfer at 2.5M bits per second at distances up to 1000 feet; up to 1.25M bits per second at distances up to 2000 feet. Device is designed for maximum flexibility and ease of use, plugs directly into I/O structure of each 2100 to be linked, is fully supported under standard warranty terms.

Interface card is supplied with software driver compatible with HP's new data communications-oriented disc-operating system, DOS-III.

Circle 103 on Readers Service Card

Hivoltage Amplifier

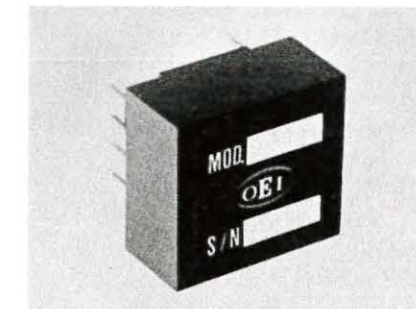

New high performance high voltage FET input operational amplifier now available from Optical Electronics, Inc., designated Model 9736. Said to be "completely protected against input overvoltage drive and output short circuit conditions. Is intended for moderately fast applications in various analog systems in communication equipment, video amplifiers, nuclear instrumentation, medical equipment. Model 9736 is packaged in 1.125 inch square by 0.44 inch high module.

Circle 104 on Readers Service Card

CRT Mount Assembly

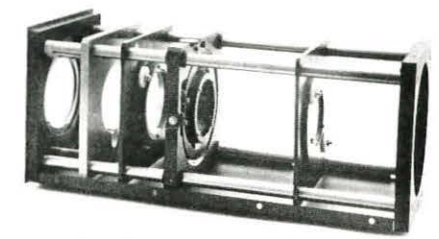

Syntronic D8300 CRT Mount Assembly is designed for maximum stability, yet is said to allow quick removal of CRT. Standard-size four-rod frame comes with Syntronic D7450 or D7675 Micropositioners for deflection yoke, focus coil or lens, and optional C7755 fixed coil positioners for holding magnetic components such as centering coils or astigmatism correction coils. Available with or without electromagnetic shield, the D8300 is said to be ideal for laboratory research, prototype evaluation, or as an accurate ready-made frame for rugged OEM applications.

Circle 105 on Readers Service Card

Tektronix Ships New Big Terminals

Tektronix says shipments have started of its new 4014 computer display terminals. The 19-inch terminal is largest direct-view storage terminal in industry.

The 4014, because of its use of direct-view bistable storage tube (DVBST) has capability of displaying stored information (stored within the phosphor) while at same time displaying dynamic information.

An integrated circuit mask can be designed, region by region, using the 4014's capabilities. Designer can display preliminary geometry for each region determine whether or not there are any apparent problems. When satisfied that all conditions, electrical and physical, are met, he can permanently store that geometry which was previously displayed in the write-through mode.

As many as 8500 alphanumeric characters and more than one million graphic points can be displayed on the graphics terminal. The 4014-1 and the 4015-1 are the hard copy compatible versions of the terminals.

Circle 106 on Readers Service Card

IEE Planar Displays

Industrial Electronic Engineers (IEE) announces introduction of new IEE-Aurora Series of incandescent, seven-segment digital displays. Operating at nominal 5VDC, and packaged in conventional 14-pin DIP flat pack configuration, these readouts provide 4,500 foot/lamberts brightness for easy reading in high ambient lighting or sunlit environments. Esthetically pleasing, slightly inclined characters are .47" high x .24" wide, are available in selected alphabetical, digital (0-9), plus/minus one (1), and right hand decimal formats.

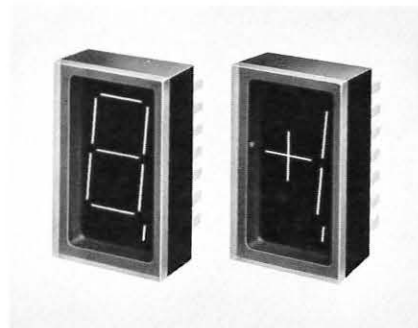

Each readout consists of seven .236" incandescent segments mounted on a single plane in a black ceramic receptacle, and sealed with a clear glass screen. High intensity, clear light and the sharp contrast inherent in the IEE-Aurora design are said offer excellent legibility through a 120° angle under practically all external lighting conditions. Full spectrum of colors for selective discrimination may be achieved through use of filters.

With seated depth of .248" (less than .5" overall including pins), .91"-high slimline units may be mounted in whatever number of decades required with .6" on-center spacing.

Circle 107 on Readers Service Card

Card Reader

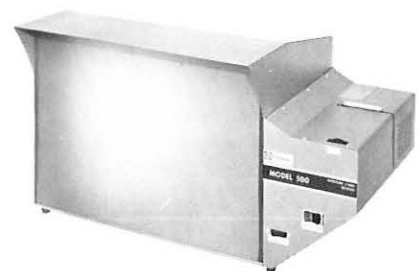

Bruning 500 aperture card reader is announced as low-priced, large-

Magnetic Switch



New Magnetic Pushbutton Switches with Push/Pull maintained action offered by Alco Electronic Products. Miniaturized cylindrical steel case is 39/64-inch long and doubles as a magnetic shield. Terminals are pin-type. Contact is made by depressing plunger where it is held closed by magnetic field. Contact is broken by exerting minimal pull on plunger to return it to its original position. Contacts are hermetically-sealed glass encapsulated reeds to give protection from moisture and contamination. Sealed contacts are also explosion-proof for use in critical environments. Standard 1/4-inch diameter threaded bushing accommodates simplified mounting. No springs are used so there are no moving parts to wear out. Life expectancy is "in excess of 1/2-million operations."

Circle 108 on Readers Service Card

screen unit "capable of displaying excellent-quality images of any standard-size aperture card."

With 14 x 20-in. blue, gray or green screen, device features 12X magnification, utilizes dual-intensity, fan-cooled quartz halogen type lamp, has electrical load/lock for constant focus. Made of steel and aluminum, Bruning 500 measures 27-3/8 x 14-3/4 x 12-3/4-in., weighs 30 lbs. It operates on regular 120 Va-c, 50/60 Hz electrical power, although 240 V1-c, 50 Hz units also are available.

Circle 109 on Readers Service Card



Bar Graph Display

Electronic "Self-Scan®" bar graph analog display device has been announced by Electronic Components Division of Burroughs Corporation. The flat panel indicator displays two separate 4-inch-long bar graphs, each containing 200 elements for 0.5% resolution. Display element glow blends into continuous, but precisely controllable bar length. Unique device is first of series of digitally-controlled analog displays that will find use in diverse panel meter applications: including, depth, level, pressure, speed and volume indicators, as well as process control gauges. Display uses easy-to-see neon orange glow, is said to be flicker free, can be easily seen in direct sunlight.

By using gas-discharge technology, thick-film processing, and Burroughs' internal self-scanning techniques, bar graph eliminates over 90% of the drive electronics and requires only eight connections to control the two independent 200 element displays.

Says Burroughs: "This new display product revolutionizes the ability of electronics to present analog data precisely with digital circuits. This was not previously possible, with either sufficient accuracy or low enough cost nor with acceptable display viewing characteristics. We anticipate the unique features of this display device will result in a great number of new applications in all areas of display instrumentation and control, including automotive, aircraft, instrumentation and consumer devices." The device is thin (0.2 inch excluding tubulation) and can be provided in special shapes and different configurations for custom applications.

Circle 110 on Readers Service Card

Activities

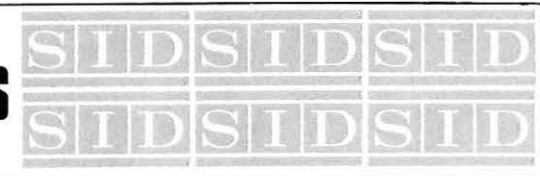

If You Heard 'Em Lucky, If You Didn't, Too Bad

SAN DIEGO CHAPTER

March 12, 1974

Host: Hughes Aircraft Industrial Products Division, Carlsbad. Demonstrations of Conographics display system; CRT product line; Direct View storage tubes; Scan Converter memory systems; Double-Ended Scan Converters; Probe System.

April 23, 1974

Speaker: James Crooks, Vice President/Engineering, General Dynamics. Engineering problems at the Space Theatre, San Diego Hall of Science, such as computer control, and light cross-bounce. A laser demonstration was given.

MINNEAPOLIS-ST. PAUL CHAPTER

April 19, 1974

Host: Arion Corporation, Minneapolis. Presentation, under direction of Bud Mickelsen and Gary White, of technics of multi-sensory presentations combining motion pictures, slides, lights, sound, etc. for audiences.

(SAN FRANCISCO) BAY AREA CHAPTER

March 19, 1974

Host: Dest Data Corporation, Sunnyvale. Tom Mallender, Executive Vice President/Technical Director, demonstrated an Optical Character Recognition (OCR) system with document-scanning, digitizing and text-editing capability. Also demonstrated was a gas bearing stage system, Dual Stereo Mensuration Stage.

Interactive Workshop

Workshop on "Interactive Computer Graphics" will be held, Boulder (Colo.), July 13-14, 1974. Sponsor is The Association for Computing Machinery Special Interest Group in Computer Graphics (SIGGRAPH). Tutorials will cover hardware, software, data structures, architecture, applications, cost benefits. Contact R.L. Schiffman, Computing Center, University of Colorado, Boulder, Colo. 80302.

MID-ATLANTIC CHAPTER

March, 1974

Host: Rutgers University Medical School, panel on Medical Diagnosis using Visual Displays. A radiologist stressed need for a real-time X-ray image display device and image processor. A psychologist discussed photosensitive epileptic seizures and electroencephalograms. An optometrist told how ERG (electroretinogram) can aid diagnosing eye ailments.

April, 1974

Speaker: James C. Greeson, Jr., Manager, Display Technology, IBM, Kingston, N.Y. He described the IBM gas discharge display panel as a component, as well as the key elements of the drive electronics.

LOS ANGELES CHAPTER

April 10, 1974

Host: Los Angeles Fire Dept. Tour of and demonstration of the computer-based information system the Fire Dept. uses to assist dispatchers in directing, controlling, coordinating fire-fighting units and rescue ambulances in the field, in real-time.

SPSE Symposium

Photoconductor Image Technology-Theory and Practice is the topic for the 1974 Summer Symposium of the Society of Photographic Scientists and Engineers, July 22, 1974, Holiday Inn, North Randall, Ohio, near Cleveland.

Three-day conference continues a series of SPSE Summer Symposia characterized by extensive opportunity for informal interaction among participants from diverse backgrounds.

Contact Dr. Evan S. Baltazzi, General Chairman, Addressograph-Multigraph Research & Development Center, 19701 South Miles Road, Warrensville Heights, Ohio 44128.

CATHODE RAY TUBES

WE OFFER YOU TECHNICAL ABILITY FOR ANY SPECIAL CRT AND DISPLAY SYSTEM

CRT
FIBER OPTIC FACE
BACK PORTED
MONOSCOPES
HIGH RESOLUTION
CUSTOM GEOMETRIES
PHOSPHOR SCREENS
ELECTRON OPTICS.



SYSTEMS
FLYING SPOT SCANNERS,
MONITORS, FIBER OPTIC
PRINTERS, DATA TERMINALS.

DESIGN — DEVELOPMENT —
PRODUCTION — TUBES AND
SYSTEMS.

M. SADOWSKY

S. CARLISLE

P. KEEGAN

SPECIAL PURPOSE TECHNOLOGY CO.

16300 LINDBERGH STREET, VAN NUYS, CALIFORNIA 91406
TELEPHONE: (213) 989-4610

Circle 8 on Readers Service Card

Calendar of Events

1974	October 9-10	1974 Conference on Display Devices and Systems Co-sponsored with Group on Electron Devices, IEEE Statler Hilton Hotel New York City
1975	April 22-24	16th International SID Symposium Shoreham Hotel Washington, D.C.
1976	May 4-6	17th International SID Symposium Beverly Hilton Hotel Los Angeles, California
1977	May 10-12	18th International SID Symposium Sheraton Hotel Boston, Massachusetts

SID Sustaining Members

ALLGEMEINE ELEKTRICITÄTS-
gesellschaft
AEG-Telefunken
Vorstandssekretariat
6 Frankfurt/Main-Sud
West Germany
AEG Hochhaus

BURROUGHS CORPORATION
Federal and Special Systems Group
Electron Components Division
Plainfield, New Jersey 07061

CHERRY ELECTRICAL PRODUCTS
CORP.
3600 Sunset Avenue
Waukegan, Illinois 60085

CONRAC CORPORATION
330 Madison Avenue
New York, New York 10017

DATA DISC INCORPORATED
686 West Maude Avenue
Sunnyvale, California 94086

DIACON, INC.
4812 Kearny Mesa Road
San Diego, California 92111

DuMONT ELECTRON TUBES
AND DEVICES CORPORATION
750 Bloomfield Avenue
Clifton, New Jersey 07015

FERRANTI ELECTRIC COMPANY
Plainview, New York

GML CORPORATION
594 Marrett Road
Lexington, Massachusetts 02173

HUGHES AIRCRAFT COMPANY
Culver City, California 90230

IBM CORPORATION
Armonk, New York

NAC INCORPORATED
17 Kowa Bldg., No. 2-7
Nishiazabu 1-Chome
Minato-ku, Tokyo, Japan

OWENS-ILLINOIS, INC.
P.O. Box 1035
Toledo, Ohio 43666

PHOTO RESEARCH DIVISION
KOLLMORGEN CORPORATION
3000 N. Hollywood Way
Burbank, California 91505

PHILCO-FORD CORPORATION
Palo Alto, California

RANK PRECISION INDUSTRIES LTD.
ELECTRONIC SYSTEMS DIVISION
Sidcup-by-Pass
Sidcup, Kent, England

SIEMENS AG
Components Marketing
76 St. Martinstr.
Munich, West Germany

SINGER-LIBRASCOPE
Aerospace & Marine Systems Group
933 Sonora Avenue
Glendale, California 91201

SYNTRONIC INSTRUMENTS, INC.
100 Industrial Road
Addison, Illinois

TEKTRONIX, INC.
Information Display Products
P.O. Box 500
Beaverton, Oregon 97005

THOMAS ELECTRONICS, INC.
100 Riverview Drive
Wayne, New Jersey 07470

THOMSON-CSF
Paris, France

XEROX DATA SYSTEMS
El Segundo, California 90245

ASIS Annual Meeting

Development and use of on-demand information services for large segments of the general public is the theme of the 37th Annual Meeting of American Society for Information Science (ASIS), October 13-17, Hyatt Regency, Atlanta, Ga. Contact Dr. Vladimir Slamecka, Georgia Institute of Technology, Atlanta, Ga. 30332. ASIS commences publication of new membership magazine, to be published 10 times a year, this Summer.

SPSE Fall Meeting

Dr. Dietrich Schultze, Scientific Director of Agfa-Gevaert, Inc., has been chosen by the Society of Photographic Scientists and Engineers to be Program Chairman for its 14th Annual Fall Symposium entitled "Advances in Applied Photographic Processing," to be held at the Marriott Twin Bridges Hotel in Washington, D.C.

Contact: Raymond A. Eynard, SPSE, P.O. Box 2001, Teterboro, NJ 07608.

Advertiser's Index

Burrough's Corporation*
CELCO (Constantine Engineering Labs. Co.)*
Comtal Corporation*
Constantine Engineering Labs. Co. (CELCO)*
Dumont Electron Tube & Devices	.7
Electro-Science Labs., Inc.*
Ferranti Electric Inc.*
General Electric*
Hewlett-Packard31
Hughes Aircraft Company*
Industrial Electronic Engineering16, 17
ISSEC*
ITT32
Kaiser Aerospace & Electronics	..21
Keltron Corporation*
Litton Industries, Inc.*
Motorola/Ged*
Optical Coating Laboratory, Inc.	..*
Photo Research26
Polacoat, Inc.*
Ramtek Corporation8
RCA*
Special Purpose Tube29
Syntronic Instruments2
Systems Research*
Thomas Electronics*
Watkins-Johnson10

*See Previous Issues

Shouldn't a CRT display reflect your system's true performance?

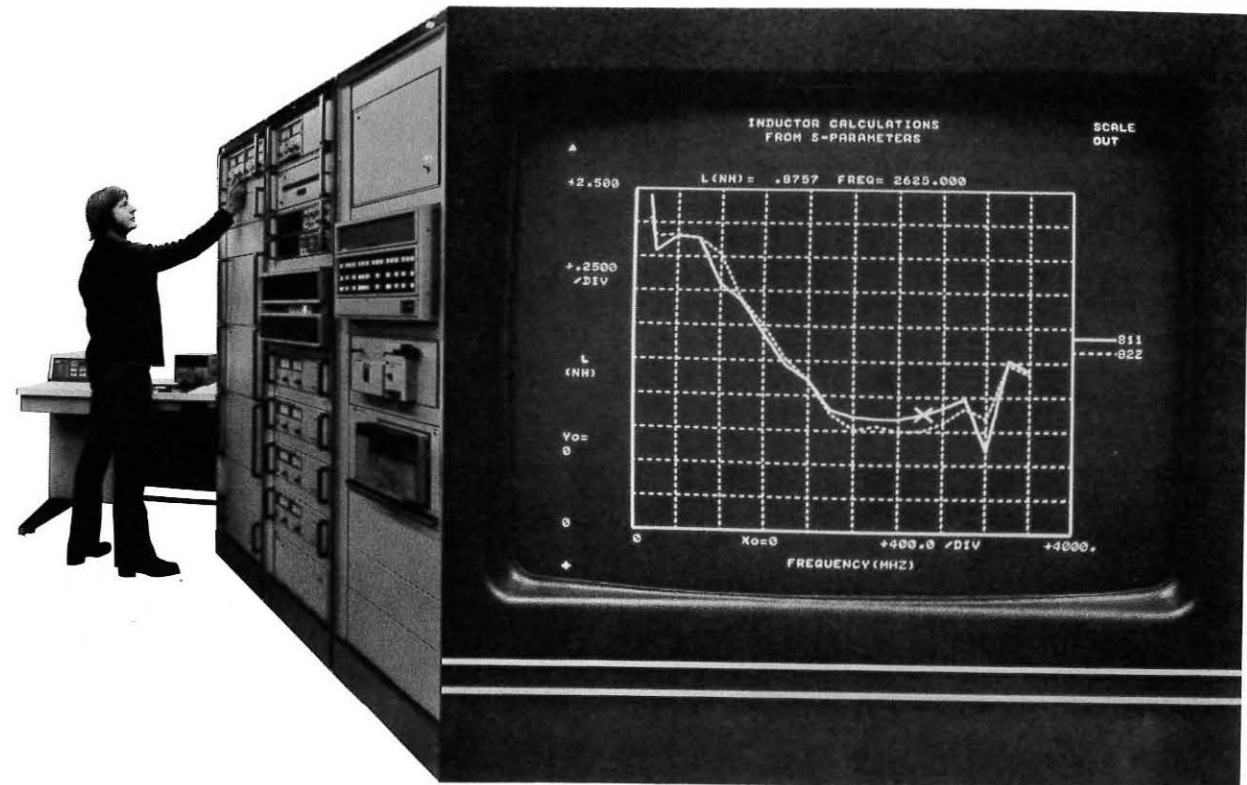

(Model 1317, 17" Diagonal Display)

Count on it with an HP display... including new large-screen models with improved performance your OEM systems demand. The high writing speed and fast settling time of our 14- through 21-inch displays means simplified output programming and greater information density in computer graphics, analytical research, radar and other display applications. Yokeless electrostatic deflection simplifies operation, eliminates geometric correction circuitry and unnecessary delay lines, and reduces required power by a factor of 5 or more. Bright, easy-to-read displays result from the 28.5 kV accelerating potential. And dy-

amic focusing assures a sharp trace at any screen location, over a wide range of intensities.

You also get versatility in HP displays. A variety of standard options allow you to tailor a display to your system's needs. Our rugged new 1317A and 1321A models give you options of TTL blanking input, differential inputs and gamma correction to match your system design and simplify interface problems. You have a choice of CRT sizes and shapes for stand-alone or rack-mounted applications. And you can get various phosphors that range from slow P7 and P39 to fast P31.

In addition to top performance

and versatility, you get the quality, reliability, and product safety you expect from a leader in CRT technology. Units are UL listed... plug-in board construction simplifies servicing...and HP's worldwide support means rapid parts replacement and service—an important consideration when you're designing a display into your system. So, for a display that reflects your system's true performance, look into HP's large-screen display family.

For more information, contact your local HP field engineer. Or, write Hewlett-Packard.

084/6A

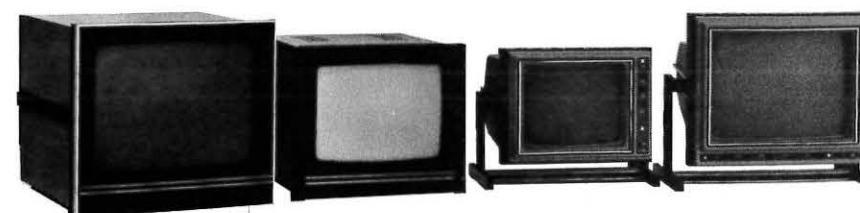

HEWLETT  PACKARD

Sales and service from 172 offices in 65 countries.
1501 Page Mill Road, Palo Alto, California 94306

Circle #9 on Readers Service Card